

Handling controversial arguments

Sylvie Coste-Marquis* — Caroline Devred** — Pierre Marquis*

* Univ. Lille Nord de France, F-59000 Lille, France

UArtois, CRIL, F-62300 Lens, France

CNRS, UMR 8188, F-62300 Lens, France

e-mail: {coste,marquis}@cril.univ-artois.fr

** LERIA/Université d'Angers

UFR Sciences

2, Bd Lavoisier

F-49045 Angers Cedex 01, France

e-mail: devred@info.univ-angers.fr

ABSTRACT. We present two prudent semantics within Dung's theory of argumentation.¹ They are based on two new notions of extension, referred to as *p-extension* and *c-extension*. Two arguments cannot belong to the same *p-extension* whenever one of them attacks indirectly the other one. Two arguments cannot belong to the same *c-extension* whenever one of them indirectly attacks a third argument while the other one indirectly defends the third. We argue that our semantics lead to a better handling of controversial arguments than Dung's ones. We compare the prudent inference relations induced by our semantics w.r.t. cautiousness; we also compare them with the inference relations induced by Dung's semantics.

KEYWORDS: argumentation, Dung's theory, prudent semantics.

DOI:10.3166/JANCL.18.1–63 © y Lavoisier, Paris

Contents

1	Introduction	2
2	Dung's theory of argumentation	5

1. This paper is a revised and extended version of (Coste-Marquis *et al.*, 2005b; Coste-Marquis *et al.*, 2005a).

3	P-extensions and c-extensions	8
4	Some properties	16
5	Comparing inference relations w.r.t. cautiousness	24
5.1	Cautiousness links between c-inference relations	25
5.2	Cautiousness links between p-inference relations	28
5.3	Cautiousness links between c-inference relations and Dung’s relations	32
5.4	Cautiousness links between p-inference relations and Dung’s relations	38
5.5	Cautiousness links between c-inference relations and p-inference relations	46
6	Some complexity results	54
7	Conclusion	57
8	References	59

1. Introduction

Argumentation is a general approach to model defeasible reasoning, in which the two main issues are the generation of arguments and their exploitation so as to draw some conclusions based on the way arguments interact (see e.g., (Toulmin, 1958; Prakken *et al.*, 2002; Besnard *et al.*, 2008)).

Several theories of argumentation have been proposed so far (see among others (Dung, 1995; Pollock, 1992; Simari *et al.*, 1992; Elvang-Gøransson *et al.*, 1995; Besnard *et al.*, 2001; Amgoud *et al.*, 2002; Dimopoulos *et al.*, 2002)). Among them is Dung’s theory² (Dung, 1995), which is quite influential since it encompasses many approaches to nonmonotonic reasoning and logic programming as special cases. In Dung’s approach, no assumption is made either on the nature of an argument or on the nature of the attack relation. Thus, nothing prevents an argumentation system from taking as input suspicious data like self-attacking or controversial arguments. Of course, Dung’s theory can be used to encode frameworks which forbid such ambiguities by the way arguments and their interactions are built. For example, an argument can be a pair (H, h) where h is a statement supported by a consistent set H of assumptions like in the theory introduced by Elvang-Gøransson *et al.* (Elvang-Gøransson *et*

2. Refined and extended by several authors, including (Baroni *et al.*, 2000; Baroni *et al.*, 2003; Caminada, 2006; Dung *et al.*, 2007).

al., 1993). In this case, (H, h) attacks (H', h') if there exists $h'' \in H'$ s.t. h is equivalent to the negation of h'' . With such a notion of attack, no self-attacking argument is possible. However, no similar conclusion can be drawn in the general case when unconstrained argumentation frameworks are considered. Indeed, Dung's theory is quite general in the sense that it can be used to encode many other argumentation frameworks with different kinds of attack relations. What really matters is the way arguments interact w.r.t. the attack relation (whatever this relation and its properties). Indeed, any argumentation framework in Dung's theory can be viewed as a labeled digraph: arguments are the nodes of the graph and attacks are represented by directed edges (i.e., arcs).

Several inference relations can be defined within Dung's theory. Usually, inference is defined at the argument level: an argument is considered derivable from an argumentation framework AF when it belongs to one (credulous consequence) (resp. all (skeptical consequence)) extensions of AF under some semantics, where an extension of AF is an admissible set of arguments (i.e., a conflict-free and self-defending set) that is maximal for a given criterion (made precise by the semantics under consideration). While skeptical derivability can be safely extended to the level of sets of arguments, this is not the case for credulous derivability. Indeed, it can be the case that arguments a and b are (individually) derivable from an argumentation framework AF while the set $\{a, b\}$ is not included in any extension of AF .

Now, defining derivability for sets of arguments as inclusion into some (resp. all) extensions under Dung's semantics does not always lead to expected conclusions. Consider the following scenario: Ally is suspected of robbery in a bookstore of Los Angeles. Several arguments and counter-arguments arise. "*Ally can not be the thief, she was in Santa Barbara at the time of the robbery (a); Bea claims that she saw Ally in Los Angeles (b); Charles pretends he was in Santa Barbara with Ally (c); Charles is Ally's boyfriend, he may lie to protect her (d); Bea is lying because she wants to cause trouble to Ally (e).*"

From an abstract point of view, the first scenario can be encoded in Dung's setting using the following argumentation framework:

EXAMPLE 1. — Let $AF = \langle A, R \rangle$ with $A = \{a, b, c, d, e\}$ and $R = \{(b, a), (e, b), (c, b), (d, c)\}$. The digraph for AF is depicted on Figure 1 on the following page. \square

AF has a single extension $\{a, d, e\}$ whatever the semantics among Dung's ones³ or alternative semantics like the semi-stable one (Caminada, 2006) or the ideal one (Dung *et al.*, 2007), hence a , d and e are considered jointly derivable. However, d attacks c so it defends b which in turn attacks a . So considering as desirable a and d at the same time may be hazardous: some people may interject that d supports an argument against a . It is not necessary to give argument c to the audience (as e defends a against b); furthermore it may be the case that using c turns against Ally (allowing d to defend b). It is thus better for Ally's defence to avoid this argument.

3. They are recalled in Section 2.

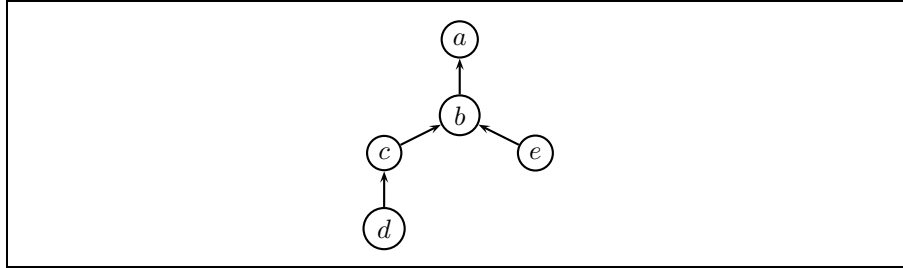

Figure 1. Example 1: The digraph for AF

One way to cope with this problem is to ask for more demanding notions of absence of conflicts than the one considered in Dung's theory. In this paper, we define and study new semantics for Dung's framework based on the idea that an admissible set S of arguments should not include controversies, i.e., it should not be the case that an element s_1 of S indirectly attacks another argument s whenever a second element s_2 of S indirectly defends s . On Example 1 on the previous page, this prevents from deriving the set of arguments $\{a, d, e\}$ as a whole; nevertheless, $\{d\}$ and $\{a, e\}$ remain derivable separately.

The specific case when $s_1 = s_2$ corresponds to the notion of controversial arguments, as introduced by Dung.

EXAMPLE 2. — Let $AF = \langle A, R \rangle$ with $A = \{a, b, c, e, n, i\}$ and $R = \{(b, a), (c, a), (n, c), (i, b), (e, c), (i, e)\}$. The digraph for AF is depicted on Figure 2. $\{a, i, n\}$ is the grounded extension of AF , it is also the stable and unique preferred

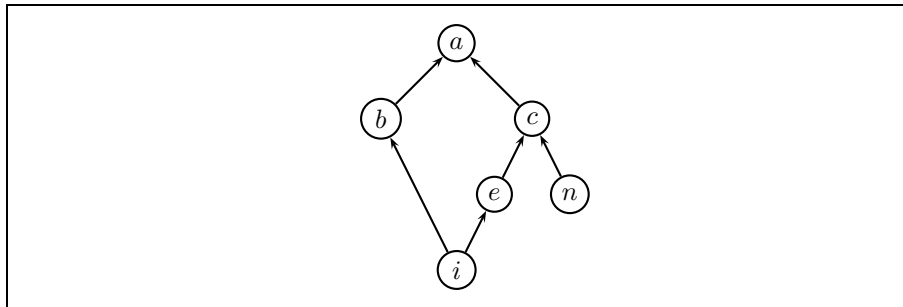

Figure 2. Example 2: The digraph for AF

extension of AF ; Hence a, i and n can be derived both credulously and skeptically under the corresponding semantics. However, we consider that it is not very cautious to derive a as its defense against b consists of i and i also attacks indirectly a . It is problematic to derive jointly a and i . \square

Thus, it is possible that an argument a belongs to an extension though its only defense against one of its attackers is an argument b controversial w.r.t. a . Is it really

cautious to rely on such an argument? Is it really cautious to handle a controversial argument in the same way as every "ordinary" argument? Can we rely on such arguments without any caution? Our point of view is that the answer is negative for the three questions.

Since Dung's semantics are not suited to address controversial arguments (as illustrated above), there is a need for new, prudent semantics. Accordingly, we propose in this paper two new semantics for taking into account controversial arguments. A first approach, consists in suppressing indirect conflicts in extensions leading to the notion of p-extension (prudent extension) (Coste-Marquis *et al.*, 2005b).

A more prudent approach consists in considering extensions S s.t. it is not possible that an element a of S attacks indirectly an argument b whenever there exists another argument $c \in S$ which indirectly defends b . This new definition of lack of conflict leads to forbid controversies within extensions and leads to the notion of c-extension (careful extension) (Coste-Marquis *et al.*, 2005a).

In this paper, we compare the different inference relations induced by our two new semantics and we also compare them with the ones obtained using Dung's framework. We show that in many cases the new semantics lead to more cautious notions of derivability.

The paper is organized as follows. We first recall the main definitions and results pertaining to Dung's theory in Section 2. Then, in Section 3, p-extensions and c-extensions are defined. Section 4 presents some properties of the new semantics. A comparison of the different notions of derivability (including a comparison with Dung's ones) is provided in Section 5. Some complexity results related to the new semantics are given in Section 6. Conclusion and perspectives for future work are given in the last section of the paper.

2. Dung's theory of argumentation

Let us present some basic definitions at work in Dung's theory of argumentation (Dung, 1995). We restrict them to finite argumentation frameworks.

DEFINITION 3 ((FINITE) ARGUMENTATION FRAMEWORKS). — *A (finite) argumentation framework is a pair $AF = \langle A, R \rangle$ where A is a finite set of so-called arguments and R is a binary relation over A (a subset of $A \times A$), the attacks relation.*

Clearly enough, the set of finite argumentation frameworks is a proper subset of the set of Dung's finitary argumentation frameworks, where every argument must be attacked by finitely many arguments. The definition above clearly shows that a finite argumentation framework is nothing but a finite, labeled digraph.

The main issue is the inference one, i.e., characterizing the sets of arguments which should be reasonably derived from a given argumentation framework.

In this objective, a first important notion is the notion of acceptability: an argument a is acceptable w.r.t. a set of arguments whenever it is defended by the set, i.e., every argument which attacks a is attacked by an element of the set.

DEFINITION 4 (ACCEPTABLE SETS). — *Let $AF = \langle A, R \rangle$ be an argumentation framework. An argument $a \in A$ is acceptable w.r.t. a subset S of A if and only if for every $b \in A$ s.t. $(b, a) \in R$, there exists $c \in S$ s.t. $(c, b) \in R$. A set of arguments is acceptable w.r.t. S when each of its elements is acceptable w.r.t. S .*

A second important notion is the notion of absence of conflicts. Intuitively, two arguments should not be considered together whenever one of them attacks the other one.

DEFINITION 5 (CONFLICT-FREE SETS). — *Let $AF = \langle A, R \rangle$ be an argumentation framework. A subset S of A is conflict-free if and only if for every $a, b \in S$, we have $(a, b) \notin R$.*

Requiring the absence of conflicts and the form of autonomy captured by self-acceptability leads to the notion of admissible set.

DEFINITION 6 (ADMISSIBLE SETS). — *Let $AF = \langle A, R \rangle$ be an argumentation framework. A subset S of A is admissible for AF if and only if S is conflict-free and acceptable w.r.t. S .*

Every argumentation framework has at least one admissible set, namely \emptyset .

The significance of the concept of admissible sets is reflected by the fact that every extension of an argumentation framework under the standard semantics introduced by Dung (preferred, stable, complete and grounded extensions) is an admissible set, satisfying some form of optimality:

DEFINITION 7 (EXTENSIONS). — *Let $AF = \langle A, R \rangle$ be an argumentation framework.*

- *A subset S of A is a preferred extension of AF if and only if it is maximal w.r.t. \subseteq among the set of admissible sets for AF .*
- *A subset S of A is a stable extension of AF if and only if it is conflict-free and for every argument a from $A \setminus S$, there exists $b \in S$ s.t. $(b, a) \in R$.*
- *A subset S of A is a complete extension of AF if and only if it is admissible and it coincides with the set of arguments acceptable w.r.t. itself.*
- *A subset S of A is the grounded extension of AF if and only if it is the least element w.r.t. \subseteq among the complete extensions of AF .*

EXAMPLE (CONTINUATION OF EXAMPLE 1 ON PAGE 3). — *Let $E = \{a, d, e\}$. E is the grounded extension of AF , the unique preferred extension of AF , the unique stable extension of AF and the unique complete extension of AF . \square*

Formally, complete extensions of AF can be characterized as the fixed points of its characteristic function \mathcal{F}_{AF} :

DEFINITION 8 (CHARACTERISTIC FUNCTIONS). — *The characteristic function \mathcal{F}_{AF} of an argumentation framework $AF = \langle A, R \rangle$ is defined as follows:*
 $\mathcal{F}_{AF} : 2^A \rightarrow 2^A$
 $\mathcal{F}_{AF}(S) = \{a \mid a \text{ is acceptable w.r.t. } S\}$.

Finally, several notions of derivability of an argument (or more generally a set of arguments) can be defined by requiring the membership to one extension (credulous acceptability) or every extension (skeptical acceptability) of a specific kind. Obviously enough, credulous acceptability and skeptical acceptability w.r.t. the grounded extension coincide, since every argumentation framework has a unique grounded extension.

Formally, we note $AF \vdash S$ where $AF = \langle A, R \rangle$ is an argumentation framework and $S \subseteq A$, to state that S is a consequence of AF under \vdash . In the following, an inference relation \vdash is based on a notion of extension, and an inference principle (credulous or skeptical), so that $AF \vdash S$ holds if and only if S is included in all (skeptical) or at least one (credulous) extension(s) of AF , for a given semantics. Formally:

NOTATION 9 (DUNG'S INFERENCE RELATIONS). — *Let $\vdash^{q,s}$ denote the Dung's inference relation obtained by considering a semantics s and an inference principle q , either credulous ($q = \exists$) or skeptical ($q = \forall$).*

For instance, $S \subseteq A$ is a consequence of $AF = \langle A, R \rangle$ w.r.t. $\vdash^{\forall,P}$, noted $AF \vdash^{\forall,P} S$, indicates that S is included in every preferred extension of AF .

Observe that other inference principles could be considered; for instance, $S \subseteq A$ can be considered as a consequence of $AF = \langle A, R \rangle$ when it is included in an extension (w.r.t. some given semantics) but no element of S is attacked by such an extension. However, for space reasons, we focus only on credulous and skeptical inference in the following.

Among other things, Dung has shown that every argumentation framework AF has at least one preferred extension, while it may have zero, one or many stable extensions. These extensions are linked up as follows (Theorem 25 in (Dung, 1995)):

PROPOSITION 10. — *Let AF be an argumentation framework.*

- 1) *Every preferred (resp. stable, complete) extension of AF contains the grounded extension of AF .*
- 2) *The grounded extension of AF is included in the intersection of all the complete extensions of AF .*

The purest argumentation frameworks AF in Dung's theory are those for which all the notions of acceptability coincide. Dung has provided a sufficient condition for an argumentation framework AF to satisfy this requirement, called the well-foundation of AF (Dung, 1995):

DEFINITION 11 (WELL-FOUNDATION). — *Let $AF = \langle A, R \rangle$ be an argumentation framework. AF is well-founded if and only if there exists no infinite sequence $a_0, a_1, a_2, \dots, a_n, \dots$ such that for each i , a_{i+1} attacks a_i .*

For a finite argumentation framework AF , AF is well-founded if and only if there is no cycle in the digraph $\langle A, R \rangle$. Theorem 30 in (Dung, 1995) states that:

THEOREM 12. — *A well-founded argumentation framework AF has exactly one complete extension, which is both the unique preferred extension, the unique stable extension and the grounded extension of AF .*

EXAMPLE (CONTINUATION OF EXAMPLE 1 ON PAGE 3). — AF has no cycle. So AF is well-founded. \square

Dung has also shown that every stable extension is preferred and every preferred extension is complete; however, none of the converse inclusions holds. When all the preferred extensions of an argumentation framework are stable ones, the framework is said to be coherent:

DEFINITION 13 (COHERENCE). — *Let $AF = \langle A, R \rangle$ be an argumentation framework. AF is coherent if and only if every preferred extension of AF is also stable.*

Coherence is a desirable property. Dung gave a sufficient condition for it based on the notion of controversial argument:

DEFINITION 14 (CONTROVERSIAL ARGUMENTS). — *Let $AF = \langle A, R \rangle$ be an argumentation framework.*

- *Let $a, b \in A$. a attacks indirectly b if and only if there exists an odd-length path from a to b in the digraph for AF . a is said to be an indirect attacker of b .*
- *Let $a, b \in A$. a defends indirectly b if and only if there exists an even-length path from a to b in the digraph for AF . The length of this path is not zero. a is said to be an indirect defender of b .*
- *Let $a, b \in A$. a is controversial w.r.t. b if and only if a attacks indirectly b and a defends indirectly b .*
- *AF is uncontroversial if and only if there is no pair a, b of arguments of A such that a is controversial w.r.t. b .*
- *AF is limited controversial if and only if there is no infinite sequence of arguments a_0, \dots, a_n, \dots of A s.t. a_{i+1} is controversial w.r.t. a_i .*

Dung has shown the following theorem (Theorem 33 in (Dung, 1995)):

THEOREM 15. — *Every uncontroversial or limited controversial argumentation framework is coherent.*

3. P-extensions and c-extensions

Let us now present our new semantics for Dung's argumentation frameworks. They are based on the notion of super-controversial pair of arguments and on the notion of absence of indirect conflicts:

DEFINITION 16 (SUPER-CONTROVERSIAL ARGUMENTS). — *Let $AF = \langle A, R \rangle$ be a finite argumentation framework and let $a, b, c \in A$. (a, b) is super-controversial w.r.t. c if and only if a attacks indirectly c and b defends indirectly c .*

EXAMPLE (CONTINUATION OF EXAMPLE 1 ON PAGE 3). — In AF , (d, e) is super-controversial w.r.t. a . \square

Obviously enough, the notion of super-controversial pair of arguments extends the notion of controversial arguments since a is controversial w.r.t. c if and only if (a, a) is super-controversial w.r.t. c . It is inspired from the notion of safety defined in (Cayrol *et al.*, 2005; Mardi *et al.*, 2005).

In order to address Example 1 on page 3 and Example 2 on page 4 in a more satisfying way, we need to reinforce Dung's notion of conflict-free set of arguments.

First we consider the notion of *controversy-free* set of arguments:

DEFINITION 17 (CONTROVERSY-FREE SETS). — Let $AF = \langle A, R \rangle$ be a finite argumentation framework. $S \subseteq A$ is controversy-free if and only if for every $a, b \in S$ and every $c \in A$, (a, b) is not super-controversial w.r.t. c .

This notion leads to a new notion of admissibility:

DEFINITION 18 (C-ADMISSIBLE SETS). — Let $AF = \langle A, R \rangle$ be a finite argumentation framework. $S \subseteq A$ is c(areful)-admissible for AF if and only if every $a \in S$ is acceptable w.r.t. S and S is conflict-free and controversy-free for AF .

EXAMPLE (CONTINUATION OF EXAMPLE 1 ON PAGE 3). — $\{d\}$, and $\{a, e\}$ and its subsets except $\{a\}$ are the c-admissible sets for AF . \square

From Definition 18, the next lemma follows immediately:

LEMMA 19. — Let a, b be two arguments of a finite argumentation framework AF . If a is controversial w.r.t. b , then $\{a\}$ cannot be included into a c-admissible set for AF .

PROOF 20. — If a is controversial w.r.t. b , then (a, a) is super-controversial w.r.t. b . Consequently, $\{a\}$ is not controversy-free. Hence a cannot belong to a c-admissible set. \blacksquare

Obviously, the absence of controversial arguments within a set is only necessary to ensure that the set is controversy-free, hence potentially c-admissible (as Example 1 on page 3 shows, this is not a sufficient condition).

Alternatively, we can refine Dung's notion of admissibility, by requiring that no indirect conflict occurs within an admissible set of arguments; this leads to the notion of *p-admissible* set:

DEFINITION 21 (P-ADMISSIBLE SETS). — Let $AF = \langle A, R \rangle$ be a finite argumentation framework. $S \subseteq A$ is p(udent)-admissible for AF if and only if every $a \in S$ is acceptable w.r.t. S and S is without indirect conflicts, i.e., there is no pair of arguments a and b of S s.t. a attacks indirectly b in AF .

EXAMPLE (CONTINUATION OF EXAMPLE 1 ON PAGE 3). — $\{d, e\}$ and its subsets, and $\{a, e\}$ and its subsets except $\{a\}$ are the p-admissible sets for AF . \square

EXAMPLE (CONTINUATION OF EXAMPLE 2 ON PAGE 4). — $\{i, n\}$ and its subsets are the p-admissible sets for AF . \square

From Definition 21 on the previous page, the next lemma follows immediately:

LEMMA 22. — *Let a, b be two arguments of a finite argumentation framework AF . If a is controversial w.r.t. b , then $\{a, b\}$ cannot be included into any p-admissible set for AF .*

PROOF 23. — If a is controversial w.r.t. b , then there is an odd-length path from a to b . Consequently, $\{a, b\}$ is not without indirect conflicts. Hence $\{a, b\}$ cannot belong to a p-admissible set. \blacksquare

Note that this lemma does not prevent a or b from belonging to a p-admissible set for AF , but not to the same one.

Actually, the absence of controversial arguments is only necessary to ensure the absence of indirect conflicts (as Example 1 on page 3 shows, it does not prove sufficient).

In particular, no arguments belonging to an odd-length cycle of AF can also belong to a p-admissible set or a c-admissible set. Thus, our approach departs from (Baroni *et al.*, 2003; Baroni *et al.*, 2004) who consider that odd-length and even-length cycles in an argumentation framework should be considered in the same way. The last two lemmas are an illustration of another point of disagreement with (Baroni *et al.*, 2005). They argue that extensions (and admissible sets) must comply with a “directionality criterion”. According to this criterion, the status of an argument only depends on its predecessors in the digraph for AF . Thus, knowing the arguments preceding the members of a set of arguments in the digraph for AF should be enough to decide whether this set of arguments is admissible or not. Yet, several authors mention that there is an issue with controversial arguments because of their behaviour towards the arguments being their successors in the digraph for AF . Ignoring the successors means to ignore the controversial argument issue. Accordingly, c-admissible and p-admissible sets of arguments and the corresponding extensions do not comply with such a “directionality criterion”.

Especially, it is not cautious to consider within a single extension the arguments of an odd-length cycle since they attack themselves indirectly. Furthermore, any argument from an odd-length cycle is controversial w.r.t. an argument of the cycle (Doutre, 2002).

Echoing Dung’s lemma, we can state the following lemma for the p-admissible sets:⁴

LEMMA 24. — *Let $AF = \langle A, R \rangle$ a finite argumentation framework, $S \subseteq A$ a p-admissible set for AF , and $a, b \in A$ such that*

1) there exist $c, d \in A$ such that $(c, a) \in R$ and $(d, b) \in R$,

4. A similar lemma can be stated for the c-admissible sets but it is useless.

- 2) a is acceptable w.r.t. S and $S \cup \{a\}$ is without indirect conflicts,
- 3) b is acceptable w.r.t. S and $S \cup \{b\}$ is without indirect conflicts.

We have:

- 1) $S' = S \cup \{a\}$ is a p -admissible set for AF ,
- 2) b is acceptable w.r.t. S' and $S' \cup \{b\}$ is without indirect conflicts.

PROOF 25. —

1) Obvious given Definition 21 on page 9.

2) It sufficient to show that $\{a, b\}$ is without indirect conflict. *Reductio ad absurdum*. Assume that a attacks indirectly b (the proof for b does not attack indirectly a is similar by symmetry). Hence, there exists an odd-length path from a to b . As a is attacked by $c \in A$ and a is acceptable w.r.t. S , there exists $c' \in S$ such that c' defends a against c . Hence, there exists an even-length path (with length equals 2) from c' to a . Hence, there exists an odd-length path from c' to b . Hence $S \cup \{b\}$ is not without indirect conflict, contradiction. ■

On this ground, one can define several notions of c -extensions and several notions of p -extensions.

Let start with the *preferred p -extensions* and the *preferred c -extensions*.

DEFINITION 26 (PREFERRED C-EXTENSIONS, PREFERRED P-EXTENSION). — *Let $AF = \langle A, R \rangle$ be a finite argumentation framework. A c -admissible set $S \subseteq A$ for AF is a preferred c -extension (resp. a preferred p -extension) of AF if and only if $\nexists S' \subseteq A$ s.t. $S \subset S'$ and S' is c -admissible (resp. p -admissible) for AF .*

EXAMPLE (CONTINUATION OF EXAMPLE 1 ON PAGE 3). — $\{a, e\}$ and $\{d\}$ are the preferred c -extensions of AF . $\{a, e\}$ and $\{d, e\}$ are the preferred p -extensions of AF . □

We have the following proposition:

PROPOSITION 27. — *Let $AF = \langle A, R \rangle$ be a finite argumentation framework.*

- 1) *The set of all c -admissible (resp. p -admissible) subsets of A for AF is a complete set of $(2^A, \subseteq)$.*
- 2) *For every c -admissible (resp. p -admissible) set $S \subseteq A$ for AF , there exists at least one preferred c -extension (resp. preferred p -extension) $E \subseteq A$ of AF s.t. $S \subseteq E$.*

PROOF 28. —

1) The set of all c -admissible sets for AF has a least element w.r.t. \subseteq since \emptyset is a c -admissible set for any AF . Futhermore, every chain of c -admissible sets w.r.t. \subseteq has a least upper bound (namely, the union of those sets). Accordingly, the set of all c -admissible sets for AF is a complete set w.r.t. \subseteq . Idem for the p -admissible sets for AF .

2) Immediate from the fact that A is finite. ■

Since \emptyset is c-admissible and p-admissible for any AF , we obtain:

COROLLARY 29. — *Every finite argumentation framework $AF = \langle A, R \rangle$ has a preferred c-extension and a preferred p-extension.*

PROOF 30. — Immediate from the fact that \emptyset is c-admissible and p-admissible and point 2. of Proposition 27 on the previous page. ■

What can be found in preferred c-extensions and in preferred p-extensions? Obviously, all non-attacked arguments belong to at least one preferred p-extension of AF , but it not the case (in general) that they belong to a preferred c-extension (see Example 1 on page 3). Nevertheless, each non-attacked argument belong at least to one preferred c-extension of AF . Furthermore, though every argument which is not attacked belongs to each preferred extension of AF , it is not the case (in general) that it belongs to every preferred c-extension (resp. preferred p-extension) of AF (see Example 1 on page 3). In this respect, preferred c-extensions and preferred p-extensions hardly contrast with preferred extensions.

Let us now consider the notion of *stable c-extensions* and *stable p-extensions*:

DEFINITION 31 (STABLE C-EXTENSIONS, STABLE P-EXTENSION). — *Let $AF = \langle A, R \rangle$ be a finite argumentation framework. A conflict-free and controversy-free subset S of A (resp. a subset S of A without indirect conflicts) is a stable c-extension (resp. stable p-extension) of AF if and only if S attacks (in a direct way) every argument from $A \setminus S$.*

EXAMPLE (CONTINUATION OF EXAMPLE 1 ON PAGE 3). — AF has no stable c-extension and no stable p-extension. □

As for Dung's extensions, we have:

LEMMA 32. — *Every stable c-extension (resp. stable p-extension) of a finite argumentation framework AF also is a preferred c-extension (resp. preferred p-extension) of AF . The converse does not hold.*

PROOF 33. — By definition, if S is a stable c-extension (resp. stable p-extension) of AF , for every $a \in A \setminus S$, $S \cup \{a\}$ is not conflict-free. Subsequently, S is a maximal c-admissible (resp. p-admissible) set of AF w.r.t. \subseteq , i.e. a preferred c-extension (resp. preferred p-extension) of AF . The converse is not true (see Example 34).

EXAMPLE 34. — Let $AF = \langle A, R \rangle$ with $A = \{a, b, c, d, e\}$ and $R = \{(b, a), (a, b), (c, b), (d, c), (b, e)\}$. The digraph of AF is depicted Figure 3 on the facing page. $E_1 = \{b, d\}$ and $E_2 = \{a, e, d\}$ are the preferred (resp. stable) extensions of AF . E_1 and $E_p = \{a, e\}$ are the preferred p-extensions of AF and the preferred c-extension of AF , only E_1 is a stable p-extension and a stable c-extension. □

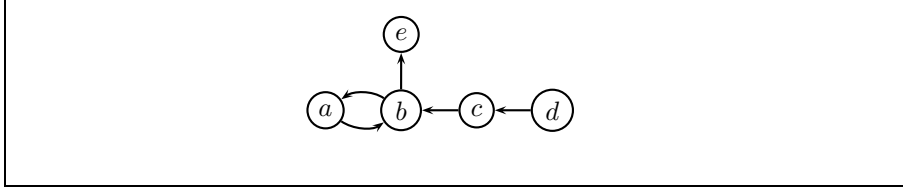

Figure 3. Example 34: The digraph of AF

Every finite argumentation framework has at least one preferred c-extension, at least one preferred p-extension, zero, one or many stable c-extensions and zero, one or many stable p-extensions.

Like stable extensions, a stable c-extension (resp. stable p-extension) cannot be empty whenever $A \neq \emptyset$.

Contrariwise to stable extensions, it is not the case that every well-founded argumentation framework has a stable c-extension or stable p-extension; furthermore, it is also not the case that every argumentation framework which is uncontroversial has a stable c-extension or stable p-extension. Example 1 on page 3 is a counter-example for both cases.

Let us now explain how c-extensions (resp. p-extension) can be characterized using some fixed point construction:

DEFINITION 35 (C-CHARACTERISTIC FUNCTIONS, P-CHARACTERISTIC FUNCTIONS). — *Let $AF = \langle A, R \rangle$ a finite argumentation framework.*

– *The c-characteristic function \mathcal{F}_{AF}^c of AF is defined as follows:*

$$\mathcal{F}_{AF}^c : 2^A \longrightarrow 2^A$$

$\mathcal{F}_{AF}^c(S) = \{a \mid a \text{ is acceptable w.r.t. } S \text{ and } S \cup \{a\} \text{ is conflict-free and controversy-free for } AF\}$.

– *The p-characteristic function of AF is defined as follows:*

$$\mathcal{F}_{AF}^p : 2^A \longrightarrow 2^A$$

$\mathcal{F}_{AF}^p(S) = \{a \mid a \text{ is acceptable w.r.t. } S \text{ and } S \cup \{a\} \text{ is without indirect conflicts}\}$.

We immediately get that:

LEMMA 36. — *Let $AF = \langle A, R \rangle$ be a finite argumentation framework and let $S \subseteq A$ be a conflict-free and controversy-free set (resp. a set without indirect conflicts) for AF . S is c-admissible (resp. p-admissible) for AF if and only if $S \subseteq \mathcal{F}_{AF}^c(S)$ (resp. $S \subseteq \mathcal{F}_{AF}^p(S)$).*

PROOF 37. —

– If way. Let $S \subseteq A$ be a conflict-free and controversy-free set (resp. a set without indirect conflicts) such that $S \subseteq \mathcal{F}_{AF}^c(S)$ (resp. $S \subseteq \mathcal{F}_{AF}^p(S)$). We have that $\forall a \in S$, a is acceptable w.r.t. S . Since S is conflict-free and controversy-free (resp. is without indirect conflicts), S is a c-admissible (resp. p-admissible) set for AF .

– Only-if way. Let S be a c-admissible (resp. p-admissible) set for AF . According to the definition of c-admissible (resp. p-admissible) sets, $\forall a \in S$, a is acceptable w.r.t. S and S is conflict-free and controversy-free (resp. without indirect conflicts). Assume that there exists $a \in S$ such that $a \notin \mathcal{F}_{AF}^c(S)$ (resp. $a \notin \mathcal{F}_{AF}^p(S)$). Since a is acceptable w.r.t. S , it must be the case that $S \cup \{a\}$ is not conflict-free or is not controversy-free (resp. is not without indirect conflicts). But $S \cup \{a\} = S$, which is both conflict-free and controversy-free (resp. without indirect conflicts), contradiction. ■

Contrariwise to the characteristic function of an argumentation framework, \mathcal{F}_{AF}^c (resp. \mathcal{F}_{AF}^p) is in general nonmonotonic w.r.t. \subseteq (and this is also the case for its restriction to the set of all c-admissible (resp. p-admissible) subsets of A). Accordingly, we cannot define a notion of grounded c-extension (resp. grounded p-extension) corresponding to the grounded one.

EXAMPLE (CONTINUATION OF EXAMPLE 1 ON PAGE 3). — Let $S_1 = \emptyset$, $S_2 = \{e\}$ and $S_3 = \{e, d\}$. $S_1 \subseteq S_2 \subseteq S_3$. S_1 and S_2 are c-admissible for AF . S_1 , S_2 and S_3 are p-admissible for AF .

$\mathcal{F}_{AF}^c(S_1) = \{d, e\}$ and $\mathcal{F}_{AF}^c(S_2) = \{e, a\}$. $\mathcal{F}_{AF}^c(S_1) \not\subseteq \mathcal{F}_{AF}^c(S_2)$, hence \mathcal{F}_{AF}^c is nonmonotonic.

$\mathcal{F}_{AF}^p(S_2) = \{d, e, a\}$ and $\mathcal{F}_{AF}^p(S_3) = \{e, d\}$. $\mathcal{F}_{AF}^p(S_2) \not\subseteq \mathcal{F}_{AF}^p(S_3)$, hence \mathcal{F}_{AF}^p is nonmonotonic. □

Nevertheless:

LEMMA 38. — Let $AF = \langle A, R \rangle$ be a finite argumentation framework. The sequence $(\mathcal{F}_{AF}^p(\emptyset))_{i \in \mathbb{N}}$ is monotonic w.r.t. \subseteq , and each element of it is a p-admissible set for AF .

PROOF 39. — By induction on i :

– Base: $i = 0$. By convention $\mathcal{F}_{AF}^{p,0}(\emptyset) = \emptyset$. Hence inclusion $\mathcal{F}_{AF}^{p,i}(\emptyset) \subseteq \mathcal{F}_{AF}^{p,i+1}(\emptyset)$ is obviously satisfied for $i = 0$. \emptyset and $\mathcal{F}_{AF}^{p,1}(\emptyset) = \{a \in A \mid a \text{ is not attacked}\}$ are obviously p-admissible sets for AF .

– Inductive step: $i > 0$. Inductive hypothesis: for $1 < k \leq i$ $\mathcal{F}_{AF}^{p,k}(\emptyset)$ is a p-admissible set and $\mathcal{F}_{AF}^{p,k-1}(\emptyset) \subseteq \mathcal{F}_{AF}^{p,k}(\emptyset)$. Is it satisfied for $i + 1$? As $\mathcal{F}_{AF}^{p,i}(\emptyset)$ is p-admissible, Lemma 36 on the previous page shows that $\mathcal{F}_{AF}^{p,i}(\emptyset) \subseteq \mathcal{F}_{AF}^p(\mathcal{F}_{AF}^{p,i}(\emptyset))$. Hence $\mathcal{F}_{AF}^{p,i}(\emptyset) \subseteq \mathcal{F}_{AF}^{p,i+1}(\emptyset)$.

Now, by definition $\mathcal{F}_{AF}^p(\mathcal{F}_{AF}^{p,i}(\emptyset)) = \{a \mid a \text{ is acceptable w.r.t. } \mathcal{F}_{AF}^{p,i}(\emptyset) \text{ and } \mathcal{F}_{AF}^{p,i}(\emptyset) \cup \{a\} \text{ is without indirect conflicts}\}$. For $1 < i$, each argument which is acceptable w.r.t. $\mathcal{F}_{AF}^{p,i}(\emptyset)$ belongs to $\mathcal{F}_{AF}^{p,1}(\emptyset)$ or is attacked. Hence, following Lemma 24 on page 10 $\mathcal{F}_{AF}^{p,i+1}(\emptyset)$ is a p-admissible set for AF . ■

Since A is finite, the sequence $(\mathcal{F}_{AF}^p(\emptyset))_{i \in \mathbb{N}}$ is stationary at some stage j , so the following definition of the *weak p-extension* of AF is well-founded:

DEFINITION 40 (WEAK P-EXTENSIONS). — Let $AF = \langle A, R \rangle$ be a finite argumentation framework. Let j be the lowest integer such that the sequence $(\mathcal{F}_{AF}^p(\emptyset))_{i \in \mathbb{N}}$ is stationary from rank j . $\mathcal{F}_{AF}^{p,j}(\emptyset)$ is the weak p-extension of AF .

EXAMPLE (CONTINUATION OF EXAMPLE 1 ON PAGE 3). — $\{d, e\}$ is the weak p-extension for AF . \square

Like the grounded extension, the weak p-extension of an argumentation framework AF includes the set of elements of A which are not attacked. Hence:

LEMMA 41. — Let $AF = \langle A, R \rangle$ be a finite argumentation framework. If AF is acyclic, then the weak p-extension of AF is nonempty.

PROOF 42. — Immediate from the definition of weak p-extension. \blacksquare

We could define in the same way a notion of weak c-extension. However, whenever there are two controversial arguments, none of these arguments could be added to this weak c-extension. Hence, this notion would be of no interest (because too much restrictive) and we do not define it.

Let us illustrate the previously introduced notions:

EXAMPLE (CONTINUATION OF EXAMPLE 1 ON PAGE 3). — $E_1 = \{a, d, e\}$ is the grounded extension, the unique stable extension and the unique preferred extension of AF . $E_2 = \{a, e\}$ and $E_3 = \{d\}$ are the preferred c-extensions for AF . There is no stable c-extension. $E_4 = \{d, e\}$ and E_2 are the preferred p-extensions for AF . E_4 is the weak p-extension of AF . There is no stable p-extension. \square

EXAMPLE (CONTINUATION OF EXAMPLE 2 ON PAGE 4). — $E_1 = \{a, i, n\}$ is the grounded extension, the unique stable extension and the unique preferred extension of AF . $E_2 = \{n\}$ is the unique preferred c-extension of AF . There is no stable c-extension. $E_3 = \{i, n\}$ is the unique preferred p-extension and the weak p-extension of AF . There is no stable p-extension. \square

EXAMPLE (CONTINUATION OF EXAMPLE 34 ON PAGE 12). — $E_1 = \{b, d\}$ and $E_2 = \{a, e, d\}$ are the preferred extensions and the stable extensions for AF . $E_3 = \{d\}$ is the grounded extension for AF . E_1 and $E_4 = \{a, e\}$ are the preferred c-extensions for AF . E_1 is the stable c-extension for AF . E_1 and E_4 are the preferred p-extensions for AF . E_1 is the stable p-extension for AF . E_3 is the weak p-extension for AF . \square

NOTATION 43 (C-INFERENCE RELATIONS, P-INFERENCE RELATIONS). — Let $\vdash_c^{q,s}$ (resp. $\vdash_p^{q,s}$) denotes the c-inference relation (resp. p-inference relation) obtained by considering a semantics s based on the c-extensions (resp. p-extension) ($s = S$ for stable, $s = P$ for preferred and $s = W$ for weak) and an inference principle q , either credulous ($q = \exists$) or skeptical ($q = \forall$).

For instance, $S \subseteq A$ is a consequence for $AF = \langle A, R \rangle$ w.r.t. $\vdash_p^{\forall,P}$, noted $AF \vdash_p^{\forall,P} S$, indicates that S is included in every preferred p-extension for AF . Since

the weak p-extension of an argumentation framework is unique, we note $\sim_p^{\exists, W} = \sim_p^{\forall, W} = \sim_p^{\cdot, W}$.

EXAMPLE 44. — Let $AF = \langle A, R \rangle$ with $A = \{a, b, c, e, n, i\}$ and $R = \{(b, e), (b, c), (c, e), (b, a), (a, i), (n, i), (i, n)\}$. The digraph for AF is depicted on Figure 4.

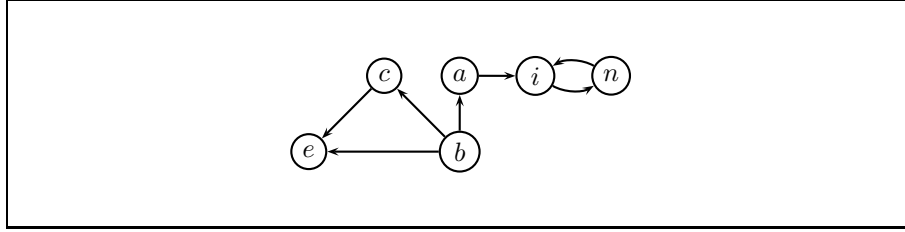

Figure 4. Example 44: The digraph for AF

$E_1 = \{b, i\}$ and $E_2 = \{b, n\}$ are the preferred extensions and the stable extensions of AF . $E_3 = \{b\}$ is the grounded extension of AF . $E_4 = \{n\}$ is the preferred c-extension of AF . There is no stable c-extension. E_1 and E_4 are the preferred p-extensions of AF . A_1 is the stable p-extension of AF and E_3 is the weak p-extension of AF .

As a consequence, we have (for instance):

- $AF \sim_p^{\exists, P} \{n\}$ and $AF \sim_c^{\exists, P} \{n\}$;
- $AF \sim_p^{\forall, P} \emptyset$ and $AF \sim_c^{\forall, P} \{n\}$;
- $AF \sim_p^{\exists, S} \{b, i\}$ and $AF \sim_c^{\exists, S} \emptyset$;
- $AF \sim_p^{\forall, S} \{b, i\}$ and $AF \sim_c^{\forall, S} A$;
- $AF \sim_p^{\cdot, W} \{d\}$.

□

4. Some properties

First of all, we have the following proposition:

PROPOSITION 45. — Let $AF = \langle A, R \rangle$ be a finite argumentation framework.

- Every c-admissible set (resp. p-admissible set) for AF is also admissible for AF . The converse does not hold.
- Every c-admissible set for AF is also a p-admissible set for AF . The converse does not hold.
- Every stable c-extension (resp. stable p-extension) of AF also is a stable extension (resp. preferred extension, complete extension) of AF . The converse does not hold.

– Every stable c -extension of AF also is a stable p -extension (resp. preferred p -extension) of AF . The converse does not hold.

PROOF 46. —

– The implication is obvious. As to the converse, in AF (see Figure 1 on page 4) $\{a, d, e\}$ is an admissible set, but it is not a c -admissible set (resp. p -admissible set) for AF .

– It is sufficient to prove that if a set $S \subseteq A$ is a c -admissible set for AF , then no element of S indirectly attacks an element of S (in other words, there does not exist an odd-length path between two elements of S). *Reductio ad absurdum*. Let $a, b \in S$ such that b indirectly attacks a . Then there exists $c \in A$ such that $(c, a) \in R$. Since S is a c -admissible set of AF and $a \in S$, a is acceptable w.r.t. S . So there exists $d \in S$ such that $(d, c) \in R$ (i.e., d defends a against c). Then (b, d) is super-controversial w.r.t. a . This contradicts the fact that S is c -admissible. As to the converse, in AF (see Figure 1 on page 4) $\{d, e\}$ is a p -admissible set, but it is not a c -admissible set.

– The implication is trivial. As to the converse, in AF (Figure 2 on page 4), $\{i, n, a\}$ is a stable extension, but it is not a stable c -extension (resp. stable p -extension) of AF .

– The implication is trivial.

EXAMPLE 47. — Let $AF = \langle A, R \rangle$ with $A = \{a, b, c, d, i, n\}$ and $R = \{(i, n), (n, a), (a, c), (c, a), (c, d), (d, c), (d, b), (b, d)\}$. The digraph for AF is depicted on Figure 5.

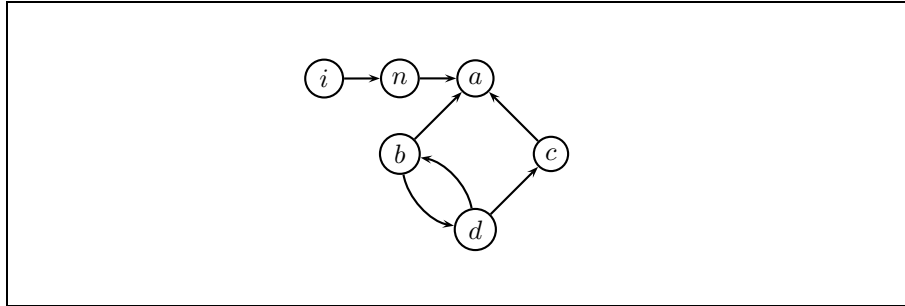

Figure 5. Example 47: The digraph for AF

$E_1 = \{i, a, d\}$ and $E_2 = \{i, b, c\}$ are the preferred extensions and the stable extensions for AF . $E_3 = \{i\}$ is the grounded extension for AF .

E_1 and $E_4 = \{b, c\}$ are the preferred c -extensions for AF . E_1 is the stable c -extension for AF .

E_1 and E_2 are the preferred p -extensions and the stable p -extensions for AF . E_3 is the weak extension for AF . \square

As to the converse, in AF (Figure 5), $E_2 = \{b, i\}$ is a stable p -extension (resp. preferred p -extension), but it is not a stable c -extension.

■

Clearly, this does not imply that every preferred c-extension is a preferred extension (resp. a preferred p-extension) which is conflict-free and controversial-free (resp. without indirect conflicts) since maximality w.r.t. set inclusion is required among c-admissible sets. Nevertheless, as a consequence of Proposition 45 on page 16, we have:

COROLLARY 48. — *Let $AF = \langle A, R \rangle$ be a finite argumentation framework.*

- *For every preferred c-extension (resp. preferred p-extension) E' de AF , there exists at least one preferred extension E of AF s.t. $E' \subseteq E$.*
- *For every preferred c-extension E_c de AF , there exists at least one preferred p-extension E_p of AF s.t. $E_c \subseteq E_p$.*

PROOF 49. —

– By definition, a preferred c-extension (resp. preferred p-extension) of AF is a c-admissible set (resp. p-admissible set) of AF . According to Proposition 45 on page 16, a c-admissible set (resp. p-admissible set) of AF is an admissible set. Dung (Dung, 1995) has shown that every admissible set of AF is included into a preferred extension of AF . Hence, each preferred c-extension (resp. preferred p-extension) of AF is included into a preferred extension of AF .

– By definition, a preferred c-extension of AF is a c-admissible set of AF . According to Proposition 45 on page 16, a c-admissible set of AF is a p-admissible set. According to Proposition 27 on page 11 every p-admissible set of AF is included into a preferred p-extension of AF . Hence, each preferred c-extension of AF is included into a preferred p-extension of AF .

■

These corollaries show in particular that when AF has a unique preferred extension E (especially, when AF is well-founded or without an even-length cycle, or trivial – i.e., when the unique preferred extension of it is empty), E includes every preferred c-extension of AF and every preferred p-extension. However, unlike preferred extensions, a well-founded argumentation framework AF can have more than one preferred c-extension and can have more than one preferred p-extension (see Example 1 on page 3).

It can also be the case that a preferred extension of AF does not include any of the preferred c-extensions (resp. preferred p-extensions) of AF , and the presence of even-length cycles in AF does not prevent it from having a unique preferred c-extension (resp. preferred p-extension). The two points are illustrated by the following example:

EXAMPLE 50. — Let $AF = \langle A, R \rangle$ avec $A = \{v, s, r, u, o, n\}$ and $R = \{(r, v), (v, r), (s, v), (r, s), (r, u), (u, o), (o, n), (n, o)\}$. The digraph of AF is depicted on Figure 6 on the facing page.

$E_1 = \{r, o\}$ and $E_2 = \{r, n\}$ are the preferred extensions and the stable extensions of AF . $E_3 = \emptyset$ is the grounded extension of AF . $E_4 = \{n\}$ is the preferred c-extension of AF . There is no stable c-extension. E_4 is the preferred p-extension of

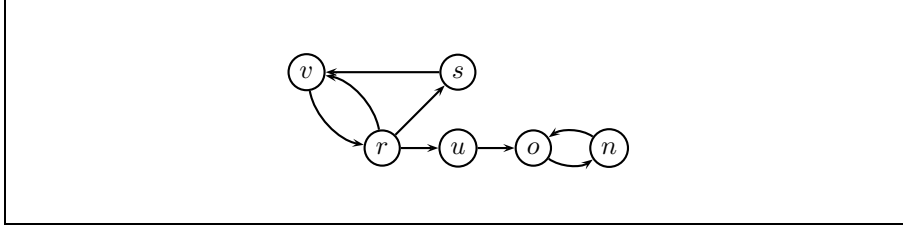

Figure 6. Example 50: The digraph of AF

AF . There is no stable p-extension. E_3 is the weak p-extension. We have $E_4 \not\subseteq E_2$. Observe that though the digraph for AF has an even-length cycle, AF has a unique preferred c-extension and a unique preferred p-extension. \square

Likewise, a preferred p-extension does not necessarily contain a preferred c-extension as shown by the following counter-example.

EXAMPLE (CONTINUATION OF EXAMPLE 44 ON PAGE 16). — There is a unique preferred c-extension $E_c = \{n\}$ and two preferred p-extensions which are E_c and $E_p = \{b, i\}$. $E_c \not\subseteq E_p$ thus E_p does not contain any preferred c-extension. \square

Another easy consequence of Proposition 45 on page 16 is that if AF is trivial, then \emptyset is the unique preferred c-extension (resp. preferred p-extension) of AF .

We now need the following lemmas to prove the following proposition.

LEMMA 51. — Let $AF = \langle A, R \rangle$ be a finite argumentation framework. For every $i > 0$, we have: $\mathcal{F}_{AF}^{p,i}(\emptyset) \subseteq \mathcal{F}_{AF}^i(\emptyset)$.

PROOF 52. — By induction on i :

– Base: $i = 0$ or $i = 1$, by convention $\mathcal{F}_{AF}^{p,0}(\emptyset) = \mathcal{F}_{AF}^0(\emptyset) = \emptyset$ and the set of non-attacked arguments of AF is $\mathcal{F}_{AF}^{p,1}(\emptyset) = \mathcal{F}_{AF}^1(\emptyset)$.

– Inductive step: Definition 8 on page 7 and Definition 35 on page 13 show that $\forall S \subseteq A$, we have $\mathcal{F}_{AF}^p(S) \subseteq \mathcal{F}_{AF}(S)$. With $S = \mathcal{F}_{AF}^{p,i}(\emptyset)$, we obtain $\mathcal{F}_{AF}^p(\mathcal{F}_{AF}^{p,i}(\emptyset)) \subseteq \mathcal{F}_{AF}(\mathcal{F}_{AF}^{p,i}(\emptyset))$. Stated otherwise, $\mathcal{F}_{AF}^{p,i+1}(\emptyset) \subseteq \mathcal{F}_{AF}(\mathcal{F}_{AF}^{p,i}(\emptyset))$. By inductive hypothesis $\mathcal{F}_{AF}^{p,i}(\emptyset) \subseteq \mathcal{F}_{AF}^i(\emptyset)$. As \mathcal{F}_{AF} is monotonic, we have $\mathcal{F}_{AF}(\mathcal{F}_{AF}^{p,i}(\emptyset)) \subseteq \mathcal{F}_{AF}(\mathcal{F}_{AF}^i(\emptyset))$, that is $\mathcal{F}_{AF}(\mathcal{F}_{AF}^{p,i}(\emptyset)) \subseteq \mathcal{F}_{AF}^{i+1}(\emptyset)$. The transitivity of \subseteq gives $\mathcal{F}_{AF}^{p,i+1}(\emptyset) \subseteq \mathcal{F}_{AF}^{i+1}(\emptyset)$. \blacksquare

As to the weak extension, one can show that:

LEMMA 53. — The weak p-extension of a finite argumentation framework AF is included into the grounded extension of AF .

PROOF 54. — Definition 40 on page 15 shows that the weak p-extension is defined as $\mathcal{F}_{AF}^{p,i}(\emptyset)$ where i is the least integer such that $\mathcal{F}_{AF}^{p,i+1}(\emptyset) = \mathcal{F}_{AF}^{p,i}(\emptyset)$.

Lemma 51 on the preceding page shows that for every $i > 0$, we have $\mathcal{F}_{AF}^{p,i}(\emptyset) \subseteq \mathcal{F}_{AF}^i(\emptyset)$.

Let j (resp. k) be the least non-null integer such that $\mathcal{F}_{AF}^{p,j+1}(\emptyset) = \mathcal{F}_{AF}^{p,j}(\emptyset)$ (resp. $\mathcal{F}_{AF}^{k+1}(\emptyset) = \mathcal{F}_{AF}^k(\emptyset)$).

1) If $j \leq k$, then we have (by Lemma 51 on the previous page) $\mathcal{F}_{AF}^{p,j}(\emptyset) \subseteq \mathcal{F}_{AF}^j(\emptyset)$. Since \mathcal{F}_{AF} is monotonic, we get $\mathcal{F}_{AF}^j(\emptyset) \subseteq \mathcal{F}_{AF}^k(\emptyset)$ and the conclusion follows.

2) If $j > k$, then we have (by Lemma 51 on the preceding page) $\mathcal{F}_{AF}^{p,j}(\emptyset) \subseteq \mathcal{F}_{AF}^j(\emptyset) = \mathcal{F}_{AF}^k(\emptyset)$. The conclusion follows. ■

The argumentation frameworks having a stable p-extension satisfy some interesting properties. We start with the link between the grounded extension and the weak p-extension under this requirement.

LEMMA 55. — *Let $AF = \langle A, R \rangle$ be a finite argumentation framework. If AF has a stable p-extension, the grounded extension of AF and the weak p-extension of AF coincide.*

PROOF 56. — Let S be a stable p-extension of AF , W_p the weak p-extension of AF and G the grounded extension of AF .

According to Lemma 51 on the previous page for all $i \in \mathbb{N}$ $\mathcal{F}_{AF}^{p,i}(\emptyset) \subseteq \mathcal{F}_{AF}^i(\emptyset)$.

Assume that $W_p \neq G$. Then there exists $i \in \mathbb{N}$ such that $\mathcal{F}_{AF}^i(\emptyset) \not\subseteq \mathcal{F}_{AF}^{p,i}(\emptyset)$. Let i_{min} be the least integer such that this property holds. Let $a \in \mathcal{F}_{AF}^{i_{min}}(\emptyset) \setminus \mathcal{F}_{AF}^{p,i_{min}}(\emptyset)$. Since $\mathcal{F}_{AF}^0(\emptyset) = \mathcal{F}_{AF}^{p,0}(\emptyset)$ (by convention $\mathcal{F}_{AF}^{p,0}(\emptyset) = \mathcal{F}_{AF}^0(\emptyset) = \emptyset$), we have $i_{min} \geq 1$. Furthermore, since $a \notin \mathcal{F}_{AF}^{p,i_{min}}(\emptyset)$ and $a \in \mathcal{F}_{AF}^{i_{min}}(\emptyset)$, there exists an indirect conflict in $\mathcal{F}_{AF}^{p,i_{min}-1}(\emptyset) \cup \{a\}$.

Thanks to Proposition 45 on page 16, we know that every stable p-extension for AF is a stable extension for A . Now, each stable extension for AF contains G (Dung, 1995). According to Lemma 53 on the previous page, $W_p \subseteq G$ and, by definition of W_p , we have $\forall i \in \mathbb{N}$, $\mathcal{F}_{AF}^{p,i}(\emptyset) \subseteq W_p$, hence we get $\mathcal{F}_{AF}^{p,i_{min}-1}(\emptyset) \subseteq S$.

Assume that $a \in S$. Since there exists an indirect conflict in $\mathcal{F}_{AF}^{p,i_{min}-1}(\emptyset) \cup \{a\}$, there exists an indirect conflict in S . This contradicts the fact that S is a stable p-extension. We have $a \notin S$. Hence there exists $b \in S$ such that $(b, a) \in R$. Since $a \in \mathcal{F}_{AF}^{i_{min}}(\emptyset)$, a is defended against b by $\mathcal{F}_{AF}^{i_{min}-1}(\emptyset)$. Hence there exists $c \in \mathcal{F}_{AF}^{i_{min}-1}(\emptyset)$ such that $(c, b) \in R$. As $\mathcal{F}_{AF}^{i_{min}-1}(\emptyset) = \mathcal{F}_{AF}^{p,i_{min}-1}(\emptyset)$, we have $c \in \mathcal{F}_{AF}^{p,i_{min}-1}(\emptyset)$, and this implies that $c \in S$.

Hence c and b both belong to S with $(c, b) \in R$. This is impossible since S must be conflict-free. ■

According to Proposition 45 on page 16, the conclusion of Lemma 55 holds when AF has a stable c-extension.

Moreover, when AF has a stable p-extension, the intersection of all preferred extensions of AF and the grounded extension of AF coincide.

PROPOSITION 57. — *Let $AF = \langle A, R \rangle$ be a finite argumentation framework. If AF has a stable p-extension, the grounded extension (resp. the weak p-extension) of AF and the intersection of all preferred extensions of AF coincide.*

PROOF 58. — According to Proposition 55 on the facing page, the weak p-extension of AF and the grounded extension of AF coincide.

Let G be the grounded extension of AF . Let S be a stable p-extension of AF . Let us note P the intersection of all preferred extensions of AF .

From Theorem 25 in (Dung, 1995), we know that $G \subseteq P$.

Assume that $P \not\subseteq G$. Then there exists $a \in P \setminus G$. Therefore a is attacked and is not defended by G against at least one of its attackers (otherwise a would belong to G). Let us consider the sequence $(E_i)_{i \in \mathbb{N}}$ of sets of arguments defined by:

- $E_0 = \{b \in A \setminus S \mid \exists a \in P \setminus G, (b, a) \in R \text{ and } \forall c \in G, (c, b) \notin R\}$.
 - $E_{i+1} = E_i \cup \{b' \in A \setminus S \mid \exists b \in E_i, \exists a \in S \setminus G, ((a, b) \in R \text{ and } (b', a) \in R)\}$
- and $\forall c \in G, (c, b') \notin G$.

$(E_i)_{i \in \mathbb{N}}$ is increasing. Since A is finite, there exists a natural integer j such that $E_{j+1} = E_j$. Let us note $E = E_j$.

According to Proposition 45 on page 16, S is a preferred extension. Hence $P \subseteq S$. Since S is conflict-free, all the attackers of $a \in P \setminus G$ belong to $A \setminus S$. Let b an attacker of a such that a is not defended against b by G (otherwise $a \in G$). By definition of E_0 , $b \in E_0$. $E_0 \subseteq E$, hence $b \in E$. Hence $E \neq \emptyset$ under the assumption that $P \setminus G \neq \emptyset$.

By construction, every element of E attacks an element of $S \setminus G$ and is not attacked by any element of G .

Furthermore, since S is a stable p-extension of AF and since, by construction, $E \cap S = \emptyset$, every element of E is attacked by an element of S , hence by an element, say a' , of $S \setminus G$. Each a' is attacked by an element of E , otherwise it would belong to G . Hence each element of E is defended by E against $S \setminus G$.

Finally, no element e of E is attacked by an element c of $(A \setminus E) \setminus S$. Indeed, if it were the case, since S is a stable p-extension of AF , S would attack c , which would attack e which, by construction of E , attacks an element of S : there would exist an odd-length path between two elements of S ; this is impossible because S is a stable p-extension.

Thus, E is acceptable w.r.t. E .

Assume now that E is conflict-free. Then E is included into a preferred extension E' of AF . By definition of P , P is included in E' . However, $E \cup P$ is not conflict-free (since $E_0 \subseteq E$ and $E_0 \cup P$ is not conflict-free by construction of E_0 , $a \in P \setminus G$ is attacked by some $b \in E_0$). Then E' cannot exist since a preferred extension must be conflict-free. Hence E is not conflict-free.

We now show that assuming that E is not conflict-free leads again to a contradiction. If E is not conflict-free then there are $b_1, b_2 \in E$ such that $(b_1, b_2) \in R$. By construction of E , there exist two arguments $a_1, a_2 \in S \setminus G$ such that $(a_1, b_1) \in R$ and $(b_2, a_2) \in R$; hence there exists an odd-length path from a_1 to a_2 (via b_1 and b_2). This contradicts the fact that S is a stable p-extension. Thus assuming that there exists $a \in P \setminus G$ leads to a contradiction. As a consequence, $P \subseteq G$.

According to Proposition 10 on page 7, $G \subseteq P$, and this concludes the proof. ■

Clearly, since a stable c-extension is a stable p-extension, in presence of a stable c-extension the grounded extension (resp. weak p-extension) of AF and the intersection of all preferred extensions of AF coincide.

PROPOSITION 59. — *Let $AF = \langle A, R \rangle$ be a finite argumentation framework. If AF has a stable p-extension, the intersection of all preferred p-extensions of AF is included in the grounded extension (resp. weak p-extension) of AF .*

PROOF 60. — The proof is very close to Proof 58 on the previous page, where P denotes the intersection of all preferred p-extensions, S a stable p-extension and G the grounded extension (or, equivalently, the weak p-extension according to Lemma 55 on page 20). Assume that $P \not\subseteq G$. Consider the set E as defined in Proof 58 and first show that E is acceptable w.r.t. E as in Proof 58.

Assume now that E is without indirect conflicts. Then, according to Proposition 27 on page 11 E is included in a preferred p-extension E' of AF . By definition of P , P is included into E' ; however $E \cup P$ is not conflict-free (since $E_0 \subseteq E$ and $E_0 \cup P$ is not conflict-free). Then E' cannot exist since a preferred p-extension must be without indirect conflict, hence conflict-free. Hence E is not without indirect conflict.

If E contains indirect conflicts then there are $b_1, b_2 \in E$ such that there exists an odd-length path from b_1 to b_2 (e.g. $(b_1, b_2) \in R$). By construction of E , there exist two arguments $a_1, a_2 \in S \subseteq G$ such that $(a_1, b_1) \in R$ and $(b_2, a_2) \in R$; hence there exists an odd-length path from a_1 to a_2 (via b_1 and b_2). This contradicts the fact that S is a stable p-extension. Hence, $P \subseteq G$. ■

This proposition implies that if AF has a stable p-extension, the intersection of all preferred p-extensions is included in the intersection of all preferred extensions (resp. stable extension). This conclusion can also be drawn when AF has a stable c-extension, since a stable c-extension is a p-extension. Furthermore, in presence of a stable c-extension the intersection of all preferred c-extensions for AF is included into the grounded extension for AF .

PROPOSITION 61. — *Let $AF = \langle A, R \rangle$ be a finite argumentation framework. If AF has a stable c-extension, the intersection of all preferred c-extensions of AF is included into the grounded extension (resp. weak p-extension) of AF .*

PROOF 62. — The proof is very close to Proof 58 on the preceding page, where P denotes the intersection of all preferred c-extensions, S a stable c-extension and G the grounded extension (or, equivalently, the weak p-extension according to Lemma 55).

Assume that $P \not\subseteq G$. Consider the set E as defined in Proof 58 and first show that E is acceptable w.r.t. E as in Proof 58.

Assume now that E is conflict-free and controversy-free. Then, according to Proposition 27 on page 11 E is included in a preferred c-extension E' of AF . By definition of P , P is included into E' ; however $E \cup P$ is not conflict-free (since $E_0 \subseteq E$ and $E_0 \cup P$ is not conflict-free). Then E' cannot exist since a preferred c-extension must be conflict-free. Hence E is not conflict-free or not controversy-free.

We now show that assuming that E is conflict-free or controversy-free leads again to a contradiction.

- Assume that there exist $b_1, b_2 \in E$ such that $(b_1, b_2) \in R$. Since, by construction of E , $E \cap S = \emptyset$ and since no element of E is attacked by an element of G , there exist two arguments $a_1, a_2 \in S \setminus G$ such that $(a_1, b_1) \in R$ and $(a_2, b_2) \in R$; hence there exist an odd-length path from a_2 to b_2 , and an even-length path from a_1 to b_2 (via b_1). Consequently, (a_2, a_1) is super-controversial w.r.t. b_2 ; this contradicts the fact that S is a stable c-extension.

- Assume that there exist $b_1, b_2 \in E$, $d \in A$ such that (b_1, b_2) is super-controversial w.r.t. d (i.e., there exists an odd-length path from b_1 to d , and an even-length path from b_2 to d). Since by construction of E , $E \cap S = \emptyset$ and no element of E is attacked by a element of G , there exist two arguments $a_1, a_2 \in S \setminus G$ such that $(a_1, b_1) \in R$ and $(a_2, b_2) \in R$. Then there exist an odd-length path from a_2 to d (via b_2), and an even-length path from a_1 to d (via b_1). Consequently, (a_2, a_1) is super-controversial w.r.t. d : this contradicts the fact that S is a stable c-extension.

Thus, assuming that there exists $a \in P \setminus G$ leads to a contradiction. As a consequence, $P \subseteq G$. ■

According to (Dung, 1995), the grounded extension is included in each preferred (resp. stable) extension, hence the intersection of all preferred c-extensions is included in each preferred extension.

What is the influence of the presence of a stable c-extension on the presence of controversial arguments? To clarify it, we first need to state the following lemma:

LEMMA 63. — *Let $AF = \langle A, R \rangle$ be a finite argumentation framework. AF is limited controversial if and only if AF has no odd-length cycle.*

PROOF 64. —

- "If way": assume that AF is not limited controversial. Then there exists an infinite sequence $S = a_0, \dots, a_n, \dots$ of arguments from A such that a_{i+1} is controversial w.r.t. a_i for every i . Since A is finite, there exist i, j with $i \leq j$ such that a_i, \dots, a_j is a subsequence of S and a_j is controversial w.r.t. a_i . Since an argument is controversial w.r.t. to a second argument whenever there exist both an odd-length path and an even-length path from the first argument to the second, a_i, \dots, a_j is an odd-length cycle of arguments from AF .

- "Only-if way": see (Doutre, 2002).

■

From this lemma, we can prove the following:

LEMMA 65. — *Let $AF = \langle A, R \rangle$ be a finite argumentation framework. If AF has a stable c-extension, then AF is limited controversial.*

PROOF 66. — Assume that AF has a stable c-extension S and that AF is not limited controversial. Then, from Lemma 63 on the preceding page, there exists an odd-length cycle in the digraph for AF . Let a be any element of this cycle. According to (Doutre, 2002), there exists $b \in A$ such that a is controversial w.r.t. b . Then (a, a) is super-controversial w.r.t. b . Since S is conflict-free and controversial-free, we have that $a \notin S$. Hence there exists $c \in S$ such that $(c, a) \in R$. Then (c, c) is super-controversial w.r.t. b , which contradicts the fact that S is a stable c-extension of AF . ■

As a consequence:

COROLLARY 67. — *Let $AF = \langle A, R \rangle$ be a finite argumentation framework. If AF has a stable c-extension, then AF is coherent.*

PROOF 68. — Since AF has a stable c-extension, from Lemma 65, AF is limited controversial. Then, from Theorem 33 in (Dung, 1995), AF is coherent. ■

Hence, we have:

PROPOSITION 69. — *Let $AF = \langle A, R \rangle$ be a finite argumentation framework s.t. AF has a stable c-extension. For each preferred c-extension E_c of AF , there exists at least one stable extension S of AF s.t. $E_c \subseteq S$.*

PROOF 70. — Since AF has a stable c-extension, from Corollary 67, AF is coherent. Let $E_c \subseteq A$ be a preferred c-extension of AF . According to Corollary 48 on page 18, there exists a preferred extension S of AF such that $E_c \subseteq S$. Since AF is coherent, S is a stable extension of AF . ■

5. Comparing inference relations w.r.t. cautiousness

In this section, we compare w.r.t. cautiousness a number of inference relations based on the introduced semantics; we also compare them with Dung's inference relations. Cautiousness is a way to compare the inferential power of relations; it is defined in the following way: we say that $\sim_x^{q,s}$ is more cautious than $\sim_{x'}^{q',s'}$, noted $\sim_x^{q,s} \subseteq \sim_{x'}^{q',s'}$ if and only if for each $AF = \langle A, R \rangle$ and each $S \subseteq A$, if $AF \sim_x^{q,s} S$ then $AF \sim_{x'}^{q',s'} S$.

We remind that according to Proposition 45 on page 16, for any finite argumentation framework, the existence of a stable c-extension imposes the existence of a stable p-extension and of a stable extension; furthermore, the existence of a stable p-extension imposes the existence of a stable extension.

We have to distinguish several cases: the argumentation systems possessing a stable c-extension and those not possessing a stable c-extension, but a stable p-extension; those possessing a stable extension, but not possessing a stable p-extension; and finally those not possessing a stable extension. Indeed if AF has no stable extension (resp. stable c-extension, stable p-extension), then $\sim^{\forall,S}$ (resp. $\sim_c^{\forall,S}$, $\sim_p^{\forall,S}$) and $\sim^{\exists,S}$ (resp. $\sim_c^{\exists,S}$, $\sim_p^{\exists,S}$) trivialize: every set of argument belongs to the image of AF by $\sim^{\forall,S}$ (resp. $\sim_c^{\forall,S}$, $\sim_p^{\forall,S}$) and no set of argument belongs to the image of AF by $\sim^{\exists,S}$ (resp. $\sim_c^{\exists,S}$, $\sim_p^{\exists,S}$). In such a pathological scenario, credulous inference w.r.t. the stable semantics (resp. the semantics based on the stable c-extension, the semantics based on the stable p-extension) is strictly more cautious than skeptical inference w.r.t. the stable semantics (resp. the semantics based on the stable c-extension, the semantics based on the stable p-extension), which is unexpected.

5.1. Cautiousness links between c-inference relations

The cautiousness links between c-inference relations is summarized in the two following propositions.

PROPOSITION 71. — *The cautiousness links reported in Table 1 hold for every finite argumentation framework which has a stable c-extension.*

Table 1. *Cautiousness links between c-inference relations in presence of a stable c-extension*

	$\sim_c^{\exists,P}$	$\sim_c^{\exists,S}$	$\sim_c^{\forall,P}$	$\sim_c^{\forall,S}$
$\sim_c^{\exists,P}$	\subseteq	$\not\subseteq$ 1	$\not\subseteq$ 2	$\not\subseteq$ 3
$\sim_c^{\exists,S}$	\subseteq 4	\subseteq	$\not\subseteq$ 5	$\not\subseteq$ 6
$\sim_c^{\forall,P}$	\subseteq 7	\subseteq 8	\subseteq	\subseteq 9
$\sim_c^{\forall,S}$	\subseteq 10	\subseteq 11	$\not\subseteq$ 12	\subseteq

PROOF 72. — As AF has a stable c-extension, $\sim_c^{\forall,S}$ and $\sim_c^{\exists,S}$ do not trivialize, items 4, 7, 8, 9, 10 and 11 follow immediately from the definition of c-inference relation, Lemma 32 on page 12 and the transitivity of \subseteq . Hence, we have the following chain of cautiousness links (I):

$$\sim_c^{\forall,P} \subseteq \sim_c^{\forall,S} \subseteq \sim_c^{\exists,S} \subseteq \sim_c^{\exists,P}.$$

As to the remaining items:

- 1) For non-inclusion, in AF (ex. 47 on page 17, Figure 5 on page 17), $\{b\}$ is included into a preferred c-extension, but it is not included into a stable c-extension.
- 2) Non-inclusion comes from item 12 and (I) showing that $\sim_c^{\forall,S} \subseteq \sim_c^{\exists,P}$.

3) Non-inclusion comes from item 6 and (I) showing that $\mathcal{H}_c^{\exists,S} \subseteq \mathcal{H}_c^{\exists,P}$.

5) Non-inclusion comes from item 12 and (I) showing that $\mathcal{H}_c^{\forall,S} \subseteq \mathcal{H}_c^{\exists,S}$.

6) For non-inclusion, in AF (ex. 73, Figure 7), $\{d\}$ is included into a stable c-extension, but it is not included into every stable c-extension.

EXAMPLE 73. — Let $AF = \langle A, R \rangle$ with $A = \{a, b, c, d\}$ and $R = \{(b, a), (c, b), (d, c), (c, d)\}$. The digraph for AF is depicted on Figure 7.

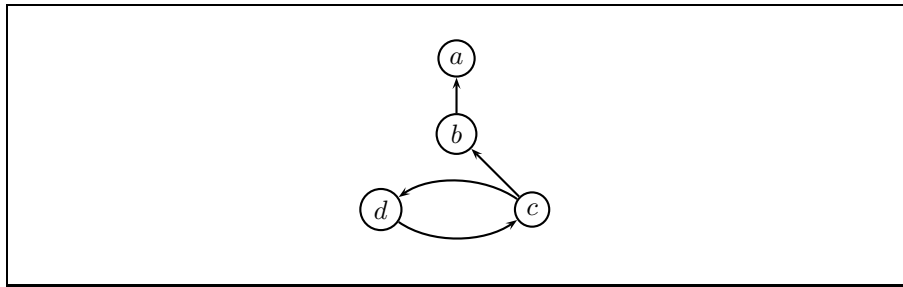

Figure 7. Example 73: The digraph for AF

$\{d, b\}$ and $\{c, a\}$ are the preferred extensions, the stable extensions, the preferred c-extensions, the stable c-extensions, the preferred p-extensions and the stable p-extensions of AF . \emptyset is the grounded extension and the weak p-extension of AF . \square

12) For non-inclusion, in AF (ex. 47 on page 17, Figure 5 on page 17), $\{d\}$ is included into every stable c-extension, but it is not included into every preferred c-extension. ■

One can note that the cautiousness picture for careful inference relations is similar to the one for the inference relations induced from Dung’s semantics (assuming that the argumentation frameworks under consideration have stable extension(s)):

$$\mathcal{H}_c^{\forall,P} \subset \mathcal{H}_c^{\forall,S} \subset \mathcal{H}_c^{\exists,S} \subset \mathcal{H}_c^{\exists,P}.$$

PROPOSITION 74. — *The cautiousness links reported in Table 2 hold for every finite argumentation framework in absence of a stable c-extension.*

Table 2. Cautiousness links between c-inference relations in absence of a stable c-extension

	$\mathcal{H}_c^{\exists,P}$	$\mathcal{H}_c^{\forall,P}$
$\mathcal{H}_c^{\exists,P}$	=	1, $\not\subseteq$
$\mathcal{H}_c^{\forall,P}$	2, \subseteq	=

PROOF 75. —

1) We consider three cases:

a) AF has a stable p-extension, hence a stable extension. In AF (ex. 8, Figure 8), $\{b\}$ is included into a preferred c-extension, but it is not included into every preferred c-extension.

EXAMPLE 76. — Let $AF = \langle A, R \rangle$ with $A = \{a, b, c, d, i, n\}$ and $R = \{(i, n), (n, a), (b, a), (c, a), (d, c), (d, b), (b, d), (n, n)\}$. The digraph for AF is depicted on Figure 8.

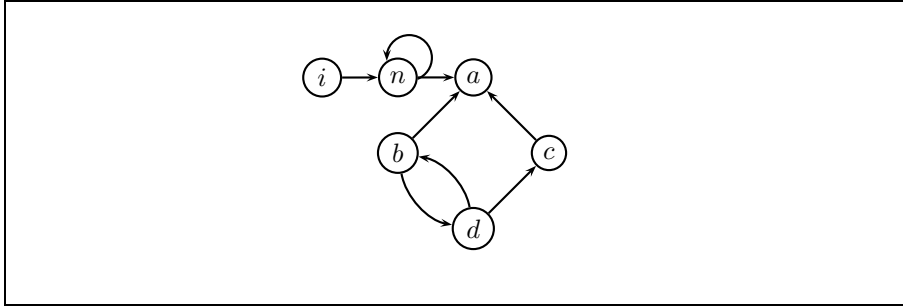

Figure 8. Example 76: The digraph for AF

$E_1 = \{i, a, d\}$ and $E_2 = \{i, b, c\}$ are the preferred extensions and the stable extensions of AF . $E_3 = \{i\}$ is the grounded extension of AF . $E'_1 = \{d\}$ and $E'_2 = \{b, c\}$ are the preferred c-extensions of AF . AF has no stable c-extension. $E''_1 = \{i, d\}$ and E_2 are the preferred p-extensions of AF . E_2 is a stable p-extension of AF . E_3 is the weak p-extension of AF . \square

b) AF has a stable extension, but no stable p-extension. In AF (ex. 1 on page 3, Figure 1 on page 4), $\{d\}$ is included into a preferred c-extension, but it is not included into every preferred c-extension.

c) AF has no stable extension. In AF (see ex. 77, Figure 9 on the next page), $\{d\}$ is included into a preferred c-extension, but it is not included into every preferred c-extension.

EXAMPLE 77. — Let $AF = \langle A, R \rangle$ with $A = \{a, b, c, d, e, i\}$ and $R = \{(b, a), (e, b), (c, b), (d, c), (i, i)\}$. The digraph for AF is depicted on Figure 9 on the following page.

$E_1 = \{a, e, d\}$ is the preferred extension and the grounded extension of AF . AF has no stable extension. $E'_1 = \{a, e\}$ and $E'_2 = \{d\}$ are the preferred c-extensions of AF . AF has no stable c-extension. E'_1 and $E''_1 = \{d, e\}$ are the preferred p-extensions of AF . AF has no stable p-extension. E''_1 is the weak p-extension of AF . \square

2) Obvious. ■

Results presented in Table 2 on the preceding page are consistent with the results presented in Table 1 on page 25.

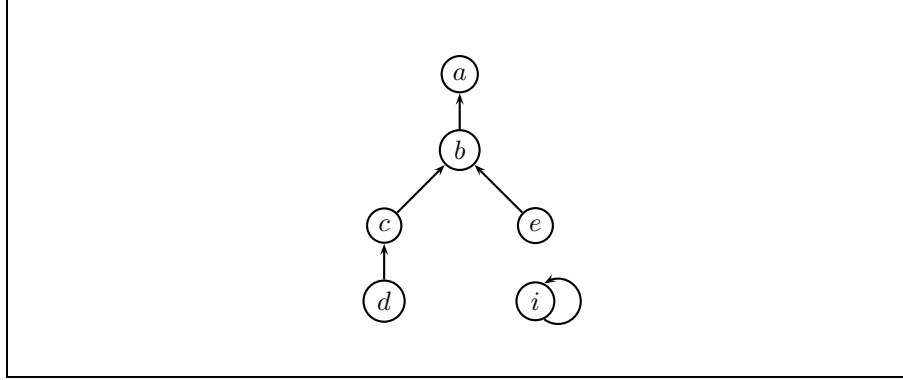

Figure 9. Example 77: The digraph for AF

5.2. Cautiousness links between p -inference relations

The cautiousness links between p -inference relations are summarized in the two following propositions.

PROPOSITION 78. — *The cautiousness links reported in Table 3 hold for every finite argumentation framework which has a stable p -extension.*

Table 3. Cautiousness links between p -inference relations in presence of a stable p -extension

	$\sim_p^{\exists,P}$	$\sim_p^{\exists,S}$	$\sim_p^{\forall,P}$	$\sim_p^{\forall,S}$	$\sim_p^{:,W}$
$\sim_p^{\exists,P}$	\subseteq	$\not\subseteq$ 1	$\not\subseteq$ 2	$\not\subseteq$ 3	$\not\subseteq$ 4
$\sim_p^{\exists,S}$	\subseteq 5	\subseteq	$\not\subseteq$ 6	$\not\subseteq$ 7	$\not\subseteq$ 8
$\sim_p^{\forall,P}$	\subseteq 9	\subseteq 10	\subset	\subseteq 11	\subseteq 12
$\sim_p^{\forall,S}$	\subseteq 13	\subseteq 14	$\not\subseteq$ 15	\subseteq	$\not\subseteq$ 16
$\sim_p^{:,W}$	\subseteq 17	\subseteq 18	$\not\subseteq$ 19	\subseteq 20	\subseteq

PROOF 79. — From the definitions of the inference relations, Lemma 32 on page 12 and transitivity of \subseteq , item 3, 5, 9, 10, 11, 13, and 14 are satisfied and the following chain of cautiousness links (II) holds:

$$\sim_p^{\forall,P} \subseteq \sim_p^{\forall,S} \subseteq \sim_p^{\exists,S} \subseteq \sim_p^{\exists,P}.$$

As to the other items, we distinguish (when necessary) two cases: In item a AF has a stable c -extension and in item b AF has a stable p -extension, but no stable c -extension.

- 1) a) For non-inclusion, in AF (ex. 34 on page 12, Figure 3 on page 13), $\{e\}$ is included into a preferred p -extension, but it is not included into a stable p -extension.

b) For non-inclusion, in AF (ex. 76 on page 27, Figure 8 on page 27), $\{d\}$ is included into a preferred p-extension, but it is not included into a stable p-extension.

2) Non-inclusion comes from item 15 and (II) showing that $\sim_p^{\forall,S} \subseteq \sim_p^{\exists,P}$.

4) Non-inclusion comes from item 16 and (II) showing that $\sim_p^{\forall,S} \subseteq \sim_p^{\exists,P}$.

6) Non-inclusion comes from item 15 and (II) showing that $\sim_p^{\forall,S} \subseteq \sim_p^{\exists,S}$.

7) a) For non-inclusion, in AF (ex. 73 on page 26, Figure 7 on page 26), $\{a\}$ is included into a stable p-extension, but it is not included into every stable p-extension.

b) For non-inclusion, in AF (ex. 80, Figure 10), $\{i\}$ is included into a stable p-extension, but it is not included into every stable p-extension.

EXAMPLE 80. — Let $AF = \langle A, R \rangle$ with $A = \{b, c, e, n, i\}$ and $R = \{(b, e), (b, c), (c, e), (n, i), (i, n)\}$. The digraph for AF is depicted on Figure 10.

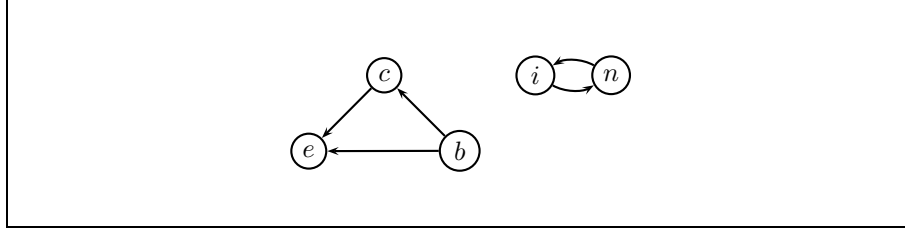

Figure 10. Exampe 80: The digraph for AF

$E_1 = \{b, i\}$ and $E_2 = \{b, n\}$ are the preferred extensions and stable extensions of AF . $E_3 = \{b\}$ is the grounded extension of AF . $E'_1 = \{i\}$ and $E'_2 = \{n\}$ are the preferred c-extensions of AF . AF has no stable c-extension. E_1 and E_2 are the preferred p-extensions and the stable p-extensions of AF . E_3 is the weak p-extension of AF . \square

8) Non-inclusion comes from item 16 and (II) showing that $\sim_p^{\forall,S} \subseteq \sim_p^{\exists,S}$.

12) Inclusion comes from Proposition 59 on page 22.

15) a) For non-inclusion, in AF , (ex. 34 on page 12, Figure 3 on page 13) $\{b\}$ is included into every stable p-extension, but it is not included into every preferred p-extension.

b) For non-inclusion, in AF (ex. 76 on page 27, Figure 8 on page 27), $\{b\}$ is included into every stable p-extension, but it is not included into every preferred p-extension.

16) a) For non-inclusion, consider AF (ex. 34 on page 12, Figure 3 on page 13), $\{b\}$ is included into every stable p-extension, but it is not included into the weak p-extension.

b) For non-inclusion, consider again AF (ex. 76 on page 27, Figure 8 on page 27), $\{b\}$ is included into every stable p-extension, but it is not included into the weak p-extension.

17) Inclusion comes from item 20 and (II) showing that $\sim_p^{\forall,S} \subseteq \sim_p^{\exists,P}$.

18) Inclusion comes from item 20 and (II) showing that $\sim_p^{\forall,S} \subseteq \sim_p^{\exists,S}$.

19) a) For non-inclusion, consider AF (ex. 34 on page 12 Figure 3 on page 13), $\{d\}$ is included into the weak p-extension, but it is not included into every preferred p-extension.

b) For non-inclusion, consider AF (ex. 81 Figure 11), $\{d\}$ is included into the weak p-extension, but it is not included into every preferred p-extension.

EXAMPLE 81. — Let $AF = \langle A, R \rangle$ with $A = \{a, b, c, d, e\}$ and $R = \{(b, a), (a, b), (c, b), (d, c), (b, e)\}$. The digraph for AF is depicted on Figure 11.

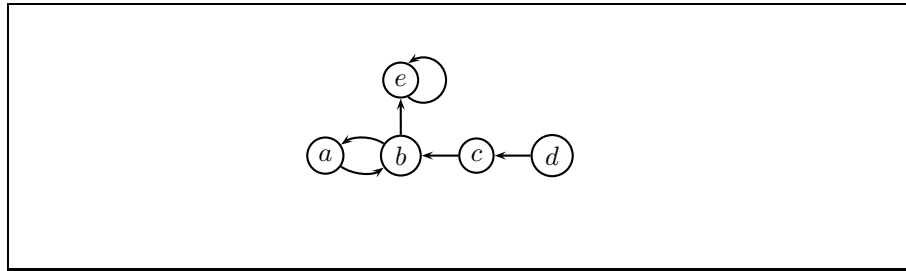

Figure 11. Example 81: The digraph for AF

$E_1 = \{b, d\}$ and $E_2 = \{a, d\}$ are the preferred extensions and the stable extensions of AF . $E_3 = \{d\}$ is the grounded extension of AF . $E'_1 = \emptyset$ is the preferred c-extension of AF . AF has no stable c-extension. E_1 and $E''_1 = \{a\}$ are the preferred p-extensions of AF . E_1 is the unique stable p-extension of AF . E_3 is the weak p-extension of AF . \square

20) According to Lemma 53 on page 19, the weak p-extension is included into the grounded extension. According to Proposition 10 on page 7, the grounded extension is included in every stable extension, hence, according to Proposition 45 on page 16 in every stable p-extension. ■

One can note that the cautiousness picture for prudent inference relations is similar to the one for the inference relations induced from Dung's semantics (assuming that the argumentation frameworks under consideration have a stable extension):

$$\mathcal{H}_p^{\forall, P} \subset \mathcal{H}_p^{\forall, S} \subset \mathcal{H}_p^{\exists, S} \subset \mathcal{H}_p^{\exists, P}.$$

PROPOSITION 82. — *Cautiousness links reported in Table 4 on the next page hold for every finite argumentation framework which has no stable p-extension.*

PROOF 83. — In item a), AF has a stable extension, but no stable p-extension. In item b), AF has no stable extension.

1) a) For non-inclusion, consider AF (ex. 1 on page 3, Figure 1 on page 4), $\{a\}$ is included into a preferred p-extension, but it is not included into every preferred p-extension.

Table 4. *Cautiousness links between p-inference relations in absence of a stable p-extension*

	$\vdash_p^{\exists,P}$	$\vdash_p^{\forall,P}$	$\vdash_p^{.,W}$
$\vdash_p^{\exists,P}$	\subseteq	$\not\subseteq_1$	$\not\subseteq_2$
$\vdash_p^{\forall,P}$	\subseteq_3	\subseteq	$\not\subseteq_4$
$\vdash_p^{.,W}$	\subseteq_5	$\not\subseteq_6$	\subseteq

b) For non-inclusion, consider AF (ex. 77 on page 27, Figure 9 on page 28), $\{a\}$ is included into a preferred p-extension, but it is not included into every preferred p-extension.

2) Non-inclusion comes from item 4 and $\vdash_p^{\forall,P} \subseteq \vdash_p^{\exists,P}$.

3) Obvious.

4) a) For non-inclusion, consider AF (ex. 84, Figure 12), $\{n\}$ is included into every preferred p-extension, but it is not included into the weak p-extension.

EXAMPLE 84. — Let $AF = \langle A, R \rangle$ with $A = \{a, b, c, d, e, i, n\}$ and $R = \{(b, a), (a, i), (c, b), (d, c), (e, c), (d, e), (a, d), (a, e), (i, n), (n, i)\}$. The digraph for AF is depicted on Figure 12. $E_1 = \{a, c, n\}$, $E_2 = \{b, d, i\}$ and $E_3 = \{b, d, n\}$ are

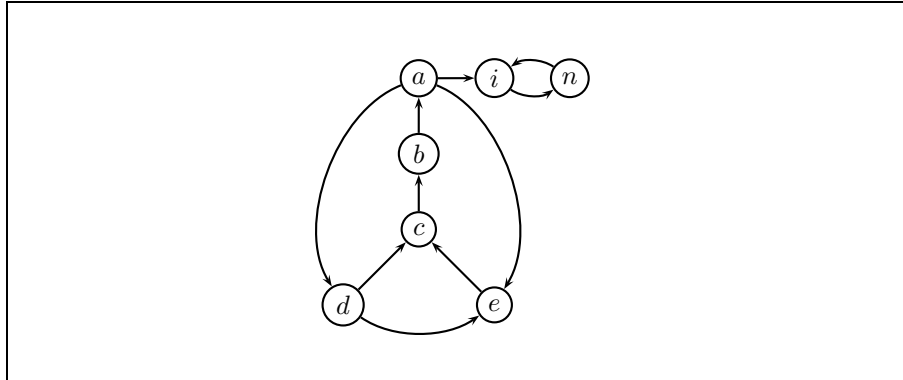
Figure 12. *Example 84: The digraph for AF*

the preferred extensions and the stable extensions of AF . $E_4 = \emptyset$ is the grounded extension of AF . $E'_1 = \{n\}$ is the unique preferred c-extension of AF . AF has no stable c-extension. $E'_1 = \{n\}$ is the unique preferred p-extension of AF . AF has no stable -extension. E_4 is the weak p-extension of AF . \square

b) For non-inclusion, in AF (ex. 85, Figure 13 on the following page), $\{n\}$ is included into every preferred p-extension, but it is not included into the weak p-extension.

EXAMPLE 85. — Let $AF = \langle A, R \rangle$ with $A = \{a, b, c, d, e, i, n, v\}$ and $R = \{(b, a), (a, i), (c, b), (d, c), (e, c), (d, e), (a, d), (a, e), (i, n), (n, i), (v, e), (v, v)\}$. The digraph for AF is depicted on Figure 13 on the next page. $E_1 = \{a, c, n\}$,

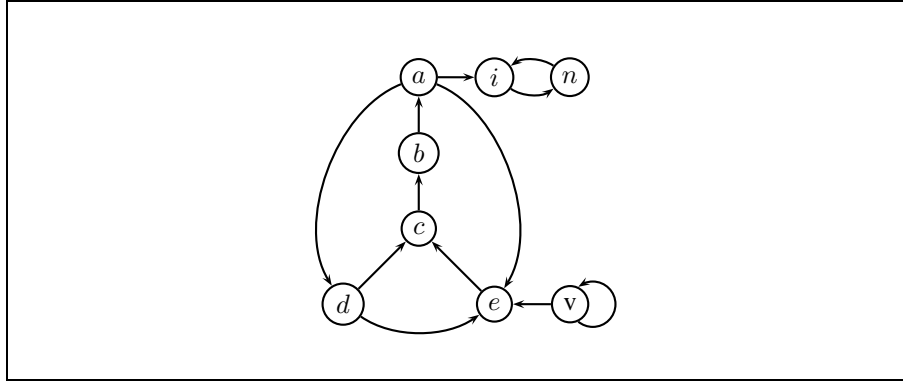

Figure 13. Example 85: The digraph for AF

$E_2 = \{d, b, i\}$ and $E_3 = \{b, d, n\}$ are the preferred extensions of AF . AF has no stable extension. $E_4 = \emptyset$ is the grounded extension of AF . $E'_1 = \{n\}$ is the unique preferred c-extension of AF . AF has no stable c-extension. E'_1 is the unique preferred p-extension of AF . AF has no stable p-extension. E_4 is the weak p-extension of AF . \square

5) Lemma 38 on page 14 and Definition 40 on page 15 show that the weak p-extension is a p-admissible set. According to Proposition 27 on page 11, the weak p-extension is included in a preferred p-extension.

6) a) For non-inclusion, consider AF (ex. 1 on page 3, Figure 1 on page 4), $\{d\}$ is included into the weak p-extension, but it is not included into every preferred p-extension.

b) For non-inclusion, consider AF (ex. 77 on page 27, Figure 9 on page 28), $\{d\}$ is included into the weak p-extension, but it is not included into every preferred p-extension.

■

5.3. Cautiousness links between c-inference relations and Dung's relations

Cautiousness links between c-inference relations and Dung's relations are summarized in the three following propositions.

PROPOSITION 86. — *Cautiousness links reported in Table 1 on page 25 hold for every finite argumentation framework which has a stable c-extension.*

PROOF 87. — According to Dung (Dung, 1995), the following chain of cautiousness links holds (III):

$$\vdash^{G} \subset \vdash^{\forall, P} \subset \vdash^{\forall, S} \subset \vdash^{\exists, S} \subset \vdash^{\exists, P}.$$

Table 5. *Cautiousness links between c-inference relations and Dung's inference relations in presence of a stable c-extension*

	$\sim_c^{\exists,P}$	$\sim_c^{\exists,S}$	$\sim_c^{\forall,P}$	$\sim_c^{\forall,S}$
$\sim_c^{\exists,P} = \sim_c^{\exists,S}$	\subseteq, \supseteq_1	\subseteq, \supseteq_2	\subseteq, \supseteq_3	\subseteq, \supseteq_4
$\sim_c^{\forall,P} = \sim_c^{\forall,S} = \sim_c^{\cdot,G}$	$\subseteq, \not\supseteq_5$	$\subseteq, \not\supseteq_6$	\subseteq, \supseteq_7	$\subseteq, \not\supseteq_8$

According to the definitions of c-inference relations, Lemma 32 on page 12 and the transitivity of \subseteq , the following chain of cautiousness links holds (I):

$$\sim_c^{\forall,P} \subseteq \sim_c^{\forall,S} \subseteq \sim_c^{\exists,S} \subseteq \sim_c^{\exists,P}.$$

Futhermore, since AF has a stable c-extension, Propositions 45 on page 16 and 57 on page 21 show that $\sim_c^{\cdot,G} = \sim_c^{\forall,P}$. In the same way, since AF has a stable c-extension, Corollary 67 on page 24 shows that $\sim_c^{\forall,P} = \sim_c^{\forall,S}$ and that $\sim_c^{\exists,S} = \sim_c^{\exists,P}$.

1) Inclusion comes from Proposition 69 on page 24. For non-inclusion, consider AF (ex. 47 on page 17, Figure 5 on page 17), $\{i, c\}$ is included into a stable extension, but it is not included into a preferred c-extension.

2) Inclusion comes from Proposition 45 on page 16. For non-inclusion, consider AF (ex. 47 on page 17, Figure 5 on page 17), $\{i, b\}$ is included into a stable extension, but it is not included into a stable c-extension.

3) Inclusion comes from item 7 and (III) showing that $\sim_c^{\cdot,G} \subseteq \sim_c^{\exists,S}$. Non-inclusion comes from item 7 and (III) showing that $\sim_c^{\cdot,G} \not\subseteq \sim_c^{\exists,S}$.

4) (I) shows $\sim_c^{\forall,S} \subseteq \sim_c^{\exists,S}$, hence according to Proposition 45 on page 16 and the transitivity of \subseteq , we have $\sim_c^{\forall,S} \subseteq \sim_c^{\exists,S}$. For non-inclusion, consider AF (ex. 47 on page 17, Figure 5 on page 17), $\{i, b\}$ is included into a stable extension, but it is not included into a preferred c-extension.

5) Inclusion and non-inclusion come from item 8 and (I) showing that $\sim_c^{\forall,S} \subseteq \sim_c^{\exists,S}$.

6) Inclusion and non-inclusion come from item 8 and (I) showing that $\sim_c^{\forall,S} \subseteq \sim_c^{\exists,S}$.

7) Inclusion comes from Proposition 61 on page 22. For non-inclusion, consider AF (ex. 47 on page 17, Figure 5 on page 17), $\{i\}$ is included into the grounded extension, but it is not included into every preferred c-extension.

8) Inclusion comes from Proposition 45 on page 16. For non-inclusion, consider AF (ex. 47 on page 17, Figure 5 on page 17), $\{a\}$ is included into every stable c-extension, but it is not included into the grounded extension. ■

Table 1 on page 25 and Table 5 are summarized on the Hasse diagram presented on Figure 14 on the next page. An arrow from R_1 to R_2 means that the inference relation R_1 is strictly more cautious than the inference relation R_2 .

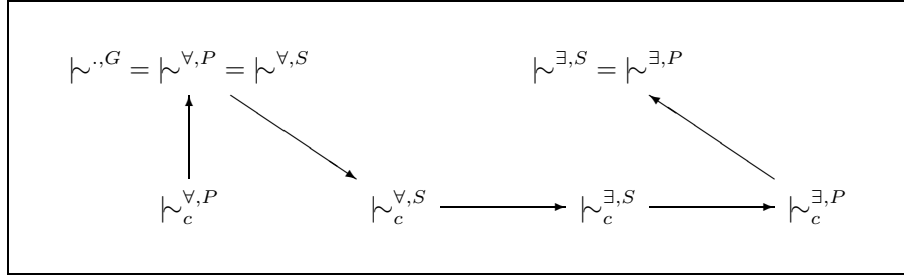

Figure 14. Cautiousness links between *c*-inference relations and Dung’s ones in presence of a stable *c*-extension

Skeptical *c*-inference under the preferred semantics is the one which has the lowest inferential power. It is even more cautious than classical inference under the grounded semantics. (Baroni *et al.*, 2005) claims that an inference relation should not be more cautious than the inference relation under Dung’s grounded extension. We do not agree with this claim: as shown in Example 2 on page 4, an argument with an hazardous defense (as *a*) may belong to the grounded extension.

EXAMPLE (CONTINUATION OF EXAMPLE 47 ON PAGE 17). — There exists a stable *c*-extension $E_1 = \{i, a, d\}$. The classical grounded extension is $E_3 = \{i\}$. If we adhere to this semantics, as (b, i) is super-controversial w.r.t. *a*, we have to reject *b*. However *b* may be acceptable as it is self-defending against its unique attacker and *b* is not controversial. So, it may be reasonable to derive also *b*. \square

As all *c*-inference relations are included into the credulous classical inference relation under the preferred semantics, the derived sets are always included into an acceptable and conflict-free set.

PROPOSITION 88. — Cautiousness links reported in Table 6 hold for every finite argumentation framework which has no stable *c*-extension, but has a stable extension.

Table 6. Cautiousness links between *c*-inference relations and Dung’s inference relations in presence of a stable extension and in absence of a stable *c*-extension

	$\sim_c^{\exists,P}$	$\sim_c^{\forall,P}$
$\sim^{\exists,P}$	\subseteq, \supseteq_1	\subseteq, \supseteq_2
$\sim^{\exists,S}$	$\subseteq, ?_3$	$\subseteq, ?_4$
$\sim^{\forall,P}$	$\subseteq, \not\supseteq_5$	$\subseteq, \not\supseteq_6$
$\sim^{\forall,S}$	$\subseteq, \not\supseteq_7$	$\subseteq, \not\supseteq_8$
$\sim^{\cdot,G}$	$\subseteq, \not\supseteq_9$	$\subseteq, \not\supseteq_{10}$

PROOF 89. — According to Dung (Dung, 1995), the following chain of cautiousness links holds (III):

$$\sim^{G} \subseteq \sim^{\forall, P} \subseteq \sim^{\forall, S} \subseteq \sim^{\exists, S} \subseteq \sim^{\exists, P}.$$

According to the definitions of c-inference relations, Lemma 32 on page 12 and transitivity of \subseteq , the following chain of cautiousness links holds (I):

$$\sim_c^{\forall, P} \subseteq \sim_c^{\forall, S} \subseteq \sim_c^{\exists, S} \subseteq \sim_c^{\exists, P}.$$

In items a), AF has a stable p-extension, but no stable c-extension. In items b), AF has no stable p-extension, but has a stable extension.

1) Non-inclusion comes from item 9 and (III) showing that $\sim^{G} \subseteq \sim^{\exists, P}$. Inclusion comes from Corollary 48 on page 18.

2) Non-inclusion comes from item 10 and (III) showing that $\sim^{G} \subseteq \sim^{\exists, P}$. Inclusion comes from Corollary 48 on page 18 and (I) showing that $\sim_c^{\forall, P} \subseteq \sim_c^{\exists, P}$.

3) Non-inclusion comes from item 9 and (III) showing that $\sim^{G} \subseteq \sim^{\exists, S}$. We do not know whether $\sim_c^{\exists, P} \subseteq \sim_c^{\exists, S}$.

4) Non-inclusion comes from item 10 and (III) showing that $\sim^{G} \subseteq \sim^{\exists, S}$. We do not know whether $\sim_c^{\forall, P} \subseteq \sim_c^{\exists, S}$.

5) The first non-inclusion comes from item 9 and (III) showing that $\sim^{G} \subseteq \sim^{\forall, P}$. The second non-inclusion comes from item 6 and (I) showing that $\sim_c^{\forall, P} \subseteq \sim_c^{\exists, P}$.

6) The first non-inclusion comes from item 10 and (III) showing that $\sim^{G} \subseteq \sim^{\forall, P}$.

a) For the second non-inclusion, consider AF (ex. 90, Figure 15), $\{n\}$ is included into every preferred c-extension, but it is not included into every preferred extension.

EXAMPLE 90. — Let $AF = \langle A, R \rangle$ with $A = \{a, b, c, e, n, i\}$ and $R = \{(b, e), (b, c), (c, e), (b, a), (a, i), (n, i), (i, n)\}$. The digraph for AF is depicted on Figure 15. $E_1 = \{b, i\}$ and $E_2 = \{b, n\}$ are the preferred extensions and the stable extensions of

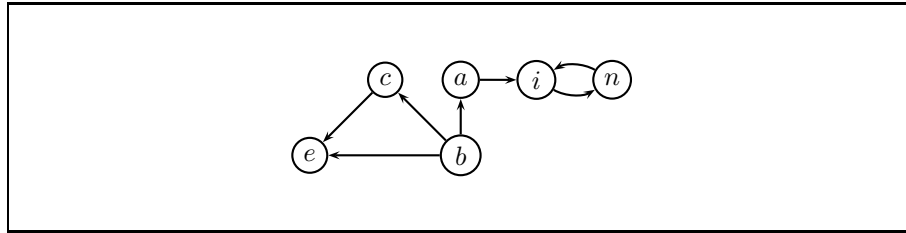

Figure 15. Example 90: The digraph for AF

AF . $E_3 = \{b\}$ is the grounded extension of AF . $E'_1 = \{n\}$ is the unique preferred c-extension of AF . AF has no stable c-extension. E_1 and E'_1 are the preferred p-extensions of AF . A_1 is the unique stable p-extension of AF . E_3 is the weak p-extension of AF . \square

b) For the second non-inclusion, consider AF (ex. 50 on page 18, Figure 6 on page 19), $\{n\}$ is included into every preferred c-extension, but it is not included into every preferred extension.

7) The first non-inclusion comes from item 9 and (III) showing that $\mathcal{H}^{\cdot,G} \subseteq \mathcal{H}^{\forall,S}$. The second non-inclusion comes from item 8 and (I) showing that $\mathcal{H}_c^{\forall,P} \subseteq \mathcal{H}_c^{\exists,P}$.

8) The first non-inclusion comes from item 10 and (III) showing that $\mathcal{H}^{\cdot,G} \subseteq \mathcal{H}^{\forall,S}$.

a) For the second non-inclusion, consider AF (ex. 90 on the previous page, Figure 15 on the preceding page), $\{n\}$ is included into every preferred c-extension, but it is not included into every stable extension.

b) For the second non-inclusion, consider AF (ex. 50 on page 18, Figure 6 on page 19), $\{n\}$ is included into every preferred c-extension, but it is not included into every stable extension.

9) a) For the first non-inclusion, consider AF (ex. 76 on page 27, Figure 8 on page 27); $\{i\}$ is included into the grounded extension, but it is not included into a preferred c-extension.

b) For the first non-inclusion, consider AF (ex. 1 on page 3, Figure 1 on page 4); $\{d, e\}$ is included into the grounded extension, but it is not included into a preferred c-extension.

The second non-inclusion comes from item 10 and (I) showing that $\mathcal{H}_c^{\forall,P} \subseteq \mathcal{H}_c^{\exists,P}$.

10) The first non-inclusion comes from item 9 and (I) showing that $\mathcal{H}_c^{\forall,P} \subseteq \mathcal{H}_c^{\exists,P}$.

a) For the second non-inclusion, consider AF (ex. 90 on the previous page, Figure 15 on the preceding page); $\{n\}$ is included into every preferred c-extension, but it is not included into the grounded extension.

b) For the second non-inclusion, consider AF (ex. 50 on page 18, Figure 6 on page 19); $\{n\}$ is included into every preferred c-extension, but it is not included into the grounded extension.

■

Table 2 on page 26 and Table 6 on page 34 are summarized on the Hasse diagram presented on Figure 16 on the next page. As in Figure 14 on page 34, plain arrows mean "strictly more cautious than". The absence of any arrow between relations mean that they are proven incomparable. Dotted arrows represent ignorance. We conjecture that $\mathcal{H}_c^{\forall,P} \subset \mathcal{H}_c^{\exists,S}$ and that $\mathcal{H}_c^{\exists,P} \subset \mathcal{H}_c^{\exists,S}$.

When there is a stable p-extension, according to Proposition 57 on page 21, we have $\mathcal{H}^{\cdot,G} = \mathcal{H}^{\forall,P}$.

As all c-inference relations are included into the classical credulous inference relation under the preferred semantics, it is possible to ensure that the derived sets are not hazardous: they are all included into an acceptable and conflict-free set. Because we do not know exactly how the c-inference relations under the preferred semantics relate to the classical credulous inference relations under the stable semantics, it is not possible to say more.

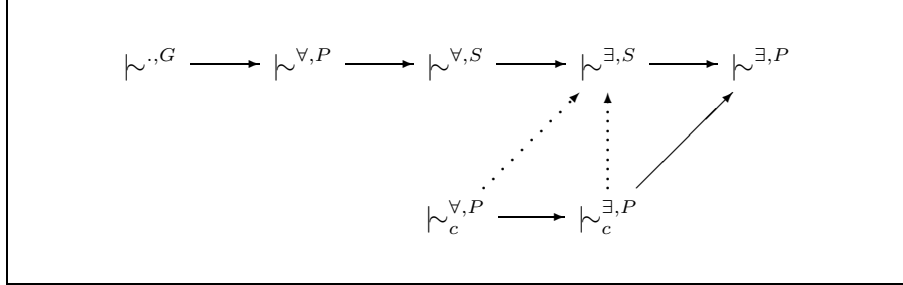

Figure 16. Cautiousness links between careful inference relations and Dung's ones in presence of stable extension and in absence of preferred c-extension

PROPOSITION 91. — *The cautiousness links reported in Table 7 hold for every finite argumentation framework which has no stable extension.*

Table 7. Cautiousness links between c-inference relations and Dung's inference relations in absence of a stable extension

	$\sim_c^{\exists,P}$	$\sim_c^{\forall,P}$
$\sim^{\exists,P}$	$\not\subseteq, \supseteq_1$	$\not\subseteq, \supseteq_2$
$\sim^{\forall,P}$	$\not\subseteq, \not\supseteq_3$	$\not\subseteq, \not\supseteq_4$
$\sim^{\cdot,G}$	$\not\subseteq, \not\supseteq_5$	$\not\subseteq, \not\supseteq_6$

PROOF 92. — According to Dung (Dung, 1995), the following chain of cautiousness links holds (III):

$$\sim^{\cdot,G} \subset \sim^{\forall,P} \subset \sim^{\forall,S} \subset \sim^{\exists,S} \subset \sim^{\exists,P}.$$

According to the definitions of c-inference relations, Lemma 32 on page 12 and the transitivity of \subseteq , the following chain of cautiousness links holds (I):

$$\sim_c^{\forall,P} \subseteq \sim_c^{\forall,S} \subseteq \sim_c^{\exists,S} \subseteq \sim_c^{\exists,P}.$$

1) Non-inclusion comes from item 5 and (III) showing that $\sim^{\cdot,G} \subseteq \sim^{\exists,P}$. Inclusion comes from Corollary 48 on page 18.

2) Non-inclusion comes item 6 and (III) showing that $\sim^{\cdot,G} \subseteq \sim^{\exists,P}$. Inclusion comes from Corollary 48 on page 18 and (I) showing that $\sim_c^{\forall,P} \subseteq \sim_c^{\exists,P}$.

3) The first non-inclusion comes item 5 and (III) showing that $\sim^{\cdot,G} \subseteq \sim^{\exists,P}$. The second non-inclusion comes from item 4 and (I) showing that $\sim_c^{\forall,P} \subseteq \sim_c^{\exists,P}$.

4) The first non-inclusion comes from item 6 and (III) showing that $\sim^{\cdot,G} \subseteq \sim^{\exists,P}$. For the second non-inclusion, consider AF (ex. 85 on page 31, Figure 13 on page 32); $\{n\}$ is included into every preferred c-extension, but it is not included into every preferred extension.

5) For the first non-inclusion, in AF (ex. 77 on page 27, Figure 9 on page 28), $\{d, e\}$ is included into the grounded extension, but it is not included into a preferred c-extension. The second non-inclusion comes item 6 and (I) showing that $\sim_c^{\forall, P} \subseteq \sim_c^{\exists, P}$.

6) The first non-inclusion comes from item 5 and (I) showing that $\sim_c^{\forall, P} = \sim_c^{\exists, P}$. For the second non-inclusion, consider AF (ex. 85 on page 31, Figure 13 on page 32); $\{n\}$ is included into every preferred c-extension, but it is not included into the grounded extension.

■

Table 2 on page 26 and Table 7 on the previous page are summarized on the Hasse diagram presented on Figure 17.

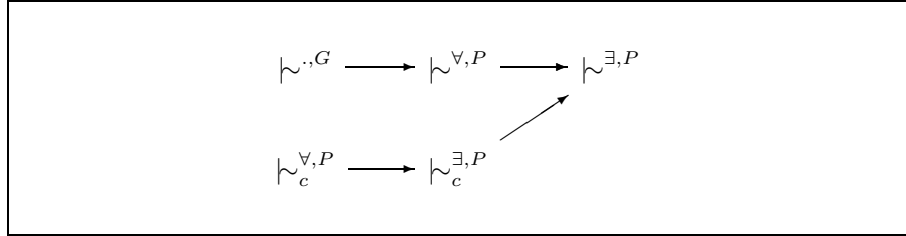

Figure 17. Cautiousness links between careful inference relations and Dung's ones in absence of stable extension

c-inference relations behave w.r.t. cautiousness like classical inference relations do - when there is no stable extension. skeptical c-inference relation under the preferred semantics is not comparable with classical inference under grounded semantics; this incomparability is expected w.r.t. previous results. It is again possible to ensure that arguments considered as hazardous by Dung cannot be derived.

5.4. Cautiousness links between p-inference relations and Dung's relations

Cautiousness links between p-inference relations and Dung's relations are summarized in the four following propositions.

PROPOSITION 93. — *Cautiousness links reported in Table 8 on the next page hold for every finite argumentation framework which has a stable c-extension.*

PROOF 94. — According to Dung (Dung, 1995), the following chain of cautiousness links holds (III):

$$\sim^{\cdot, G} \subseteq \sim^{\forall, P} \subseteq \sim^{\forall, S} \subseteq \sim^{\exists, S} \subseteq \sim^{\exists, P}.$$

According to the definitions of p-inference relations, Lemma 32 on page 12 and transitivity of \subseteq , the following chain of cautiousness links holds (II):

$$\sim_p^{\forall, P} \subseteq \sim_p^{\forall, S} \subseteq \sim_p^{\exists, S} \subseteq \sim_p^{\exists, P}.$$

Table 8. Cautiousness links between p -inference relations and Dung's inference relations in presence of a stable c -extension

	$\sim_p^{\exists,P}$	$\sim_p^{\exists,S}$	$\sim_p^{\forall,P}$	$\sim_p^{\forall,S}$
$\sim_p^{\exists,P} = \sim_p^{\exists,S}$	\subseteq, \supseteq_1	\subseteq, \supseteq_2	\subseteq, \supseteq_3	\subseteq, \supseteq_4
$\sim_p^{\forall,P} = \sim_p^{\forall,S} = \sim_p^{\cdot,G} = \sim_p^{\cdot,W}$	$\subseteq, \not\subseteq_5$	$\subseteq, \not\subseteq_6$	\subseteq, \supseteq_7	$\subseteq, \not\subseteq_8$

Furthermore, since AF has a stable c -extension, Proposition 45 on page 16 and Proposition 57 on page 21 show that $\sim_p^{\cdot,G} = \sim_p^{\forall,P}$. In the same way, since AF has a stable c -extension, Corollary 67 on page 24 shows that $\sim_p^{\forall,P} = \sim_p^{\forall,S}$ and that $\sim_p^{\exists,S} = \sim_p^{\exists,P}$. Moreover, since AF has a stable c -extension, AF has a stable p -extension, hence, according to Proposition 55 on page 20, we have $\sim_p^{\cdot,G} = \sim_p^{\cdot,W}$.

1) For non-inclusion, consider AF (ex. 34 on page 12, Figure 3 on page 13); $\{a, d\}$ is included into a stable extension, but it is not into every preferred p -extension. Inclusion comes from Corollary 48 on page 18.

2) For non-inclusion, consider AF (ex. 34 on page 12, Figure 3 on page 13); $\{a, d\}$ is included into a stable extension, but it is not included into a stable p -extension. Inclusion comes from Corollary 48 on page 18 and Proposition 45 on page 16.

3) Non-inclusion comes from item 8 and (III) showing that $\sim_p^{\cdot,G} \subseteq \sim_p^{\exists,S}$. Inclusion comes from item 8 and (III) showing that $\sim_p^{\cdot,G} \subseteq \sim_p^{\exists,S}$.

4) Non-inclusion comes from item 1 and (II) showing that $\sim_p^{\forall,S} \subseteq \sim_p^{\exists,P}$. (II) shows $\sim_p^{\forall,S} \subseteq \sim_p^{\exists,S}$. Hence, according to Proposition 45 on page 16 and transitivity of \subseteq , we have $\sim_p^{\forall,S} \subseteq \sim_p^{\exists,S}$.

5) Inclusion and non-inclusion come from item 9 and (II) showing that $\sim_p^{\forall,S} \subseteq \sim_p^{\exists,P}$.

6) Inclusion and non-inclusion come from item 9 and (II) showing that $\sim_p^{\forall,S} \subseteq \sim_p^{\exists,S}$.

7) For non-inclusion, in AF (ex. 34 on page 12, Figure 3 on page 13), $\{d\}$ is included into the grounded extension, but it is not included into every preferred p -extension. Inclusion comes from Proposition 59 on page 22.

8) Proposition 45 on page 16 shows that $\sim_p^{\forall,S} \subseteq \sim_p^{\forall,S}$. For non-inclusion, consider AF (ex. 34 on page 12, Figure 3 on page 13); $\{b\}$ is included into every stable p -extension, but it is not included into the grounded extension.

■

Table 3 on page 28 and Table 8 are summarized on the following Hasse diagram (Figure 18 on the next page).

When a stable p -extension exists, p -inference relations behave w.r.t. classical inference relations exactly in the same way as c -inference relations do (w.r.t. classical

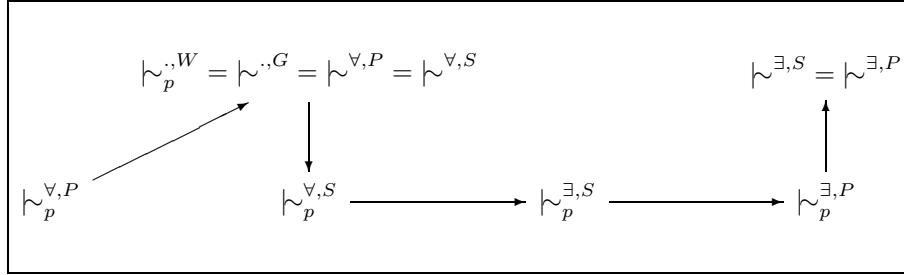

Figure 18. Cautiousness links between p -inference relations and Dung's ones in presence of stable c -extension

inference relations). Skeptical p -inference under the preferred semantics is the relation with the weakest inferential power. It is even more cautious than classical inference under the grounded semantics. Remember that, in the general case, nothing prevents the grounded extension from containing an unexpected subset of arguments (see the motivations presented on Example 2 on page 4). If the p -inference relation under the preferred semantics was in agreement with the grounded extension, all preferred p -extensions should contain every non-attacked argument. We do not want this to happen systematically. This is the reason why skeptical p -inference under the preferred semantics has this quite surprising behaviour — it does not allow to derive more than the p -inference relation using the weak p -extension.

On the other hand, all p -inference relations are included into the classical and credulous inference relations under the preferred semantics, we can ensure that none of the derived sets is hazardous (each of them is included into an acceptable conflict-free set).

PROPOSITION 95. — *The cautiousness links reported in Table 9 hold for every finite argumentation framework which has a stable p -extension, but no stable c -extension.*

Table 9. Cautiousness links between p -inference relations and Dung's inference relations in presence of a stable p -extension and in absence of a stable c -extension

	$\sim_p^{\exists, P}$	$\sim_p^{\exists, S}$	$\sim_p^{\forall, P}$	$\sim_p^{\forall, S}$
$\sim_p^{\exists, P}$	\subseteq, \supseteq_1	\subseteq, \supseteq_2	\subseteq, \supseteq_3	\subseteq, \supseteq_4
$\sim_p^{\exists, S}$	$\subseteq, \not\supseteq_5$	\subseteq, \supseteq_6	\subseteq, \supseteq_7	\subseteq, \supseteq_8
$\sim_p^{\forall, P} = \sim_p^{\cdot, G} = \sim_p^{\cdot, W}$	$\subseteq, \not\supseteq_9$	$\subseteq, \not\supseteq_{10}$	$\subseteq, \supseteq_{11}$	$\subseteq, \not\supseteq_{12}$
$\sim_p^{\forall, S}$	$\subseteq, \not\supseteq_{13}$	$\subseteq, \not\supseteq_{14}$	$\subseteq, \supseteq_{15}$	$\subseteq, \not\supseteq_{16}$

PROOF 96. — According to Dung (Dung, 1995), the following chain of cautiousness links holds (III):

$$\sim_p^{\cdot, G} \subset \sim_p^{\forall, P} \subset \sim_p^{\forall, S} \subset \sim_p^{\exists, S} \subset \sim_p^{\exists, P}.$$

According to the definitions of p-inference relations, Lemma 32 on page 12 and transitivity of \subseteq , the following chain of cautiousness links holds (II):

$$\mathcal{H}_p^{\forall, P} \subseteq \mathcal{H}_p^{\forall, S} \subseteq \mathcal{H}_p^{\exists, S} \subseteq \mathcal{H}_p^{\exists, P}.$$

Furthermore, since AF has a stable p-extension, Proposition 57 on page 21 shows that $\mathcal{H}^{\cdot, G} = \mathcal{H}^{\forall, P} = \mathcal{H}^{\cdot, W}$.

1) Non-inclusion comes from item 5 and (III) showing that $\mathcal{H}^{\exists, S} \subseteq \mathcal{H}^{\exists, P}$. Inclusion comes from Corollary 48 on page 18.

2) Non-inclusion and inclusion come from item 6 and (III) showing that $\mathcal{H}^{\exists, S} \subseteq \mathcal{H}^{\exists, P}$.

3) Non-inclusion and inclusion come from item 11 and (III) showing that $\mathcal{H}^{\cdot, G} \subseteq \mathcal{H}^{\exists, P}$.

4) Non-inclusion and inclusion come from item 8 and (III) showing that $\mathcal{H}^{\exists, S} \subseteq \mathcal{H}^{\exists, P}$.

5) For the first non-inclusion, consider AF (ex. 76 on page 27, Figure 8 on page 27); $\{a, d\}$ is included into a stable extension, but it is not included into a preferred p-extension. For the second non-inclusion, consider AF (ex. 81 on page 30, Figure 11 on page 30); $\{a\}$ is included into a preferred p-extension, but it is not included into a stable extension.

6) For non-inclusion, consider AF (ex. 76 on page 27, Figure 8 on page 27); $\{d\}$ is included into a stable extension, but is not included into a stable p-extension. Inclusion comes from Proposition 45 on page 16.

7) Non-inclusion and inclusion come from item 11 and (III) showing that $\mathcal{H}^{\cdot, G} \subseteq \mathcal{H}^{\exists, S}$.

8) For non-inclusion, consider AF (ex. 76 on page 27, Figure 8 on page 27); $\{a, d\}$ is included into a stable extension, but it is not included into a stable p-extension. (II) shows $\mathcal{H}_p^{\forall, S} \subseteq \mathcal{H}_p^{\exists, S}$. According to Proposition 45 on page 16 $\mathcal{H}_p^{\exists, S} \subseteq \mathcal{H}_p^{\exists, S}$. Transitivity of \subseteq allows to conclude that $\mathcal{H}_p^{\forall, S} \subseteq \mathcal{H}_p^{\exists, S}$.

9) Inclusion comes from item 13 and (III) showing that $\mathcal{H}^{\forall, P} \subseteq \mathcal{H}^{\forall, S}$. Non-inclusion comes from item 12 and (II) showing that $\mathcal{H}_p^{\forall, S} \subseteq \mathcal{H}_p^{\exists, P}$.

10) Inclusion comes from item 14 and (III) showing that $\mathcal{H}^{\forall, P} \subseteq \mathcal{H}^{\forall, S}$. Non-inclusion comes from item 12 and (II) showing that $\mathcal{H}_p^{\forall, S} \subseteq \mathcal{H}_p^{\exists, S}$.

11) Inclusion comes from Proposition 59 on page 22. For non-inclusion, consider AF (ex. 81 on page 30, Figure 11 on page 30); $\{d\}$ is included into the grounded extension, but it is not included into every preferred p-extension.

12) Inclusion comes from item 16 and (III) showing that $\mathcal{H}^{\forall, P} \subseteq \mathcal{H}^{\forall, S}$. For non-inclusion, consider AF (ex. 76 on page 27, fig 8 on page 27); $\{b\}$ is included into every stable p-extension, but it is not included into every preferred extension.

13) Proposition 45 on page 16 shows that $\mathcal{H}^{\forall, S} \subseteq \mathcal{H}^{\forall, S}$. (II) shows that $\mathcal{H}_p^{\forall, S} \subseteq \mathcal{H}_p^{\exists, P}$. Since \subseteq is transitive, we have $\mathcal{H}_p^{\forall, S} \subseteq \mathcal{H}_p^{\exists, P}$. Non-inclusion comes from item 16 and (II) showing that $\mathcal{H}_p^{\forall, S} \subseteq \mathcal{H}_p^{\exists, P}$.

14) Idem to item 13 replacing $\sim_p^{\exists,P}$ by $\sim_p^{\exists,S}$.

15) Non-inclusion and inclusion come from item 11 and (III) showing that $\sim^{\cdot,G} \subseteq \sim^{\exists,S}$.

16) Proposition 45 on page 16 shows that $\sim^{\forall,S} \subseteq \sim_p^{\forall,S}$. For non-inclusion, consider AF (ex. 76 on page 27, Figure 8 on page 27); $\{b\}$ is included into every stable p -extension, but it is not included into every stable extension. ■

Table 3 on page 28 and Table 9 on page 40 are summarized on the following Hasse diagram (Figure 19).

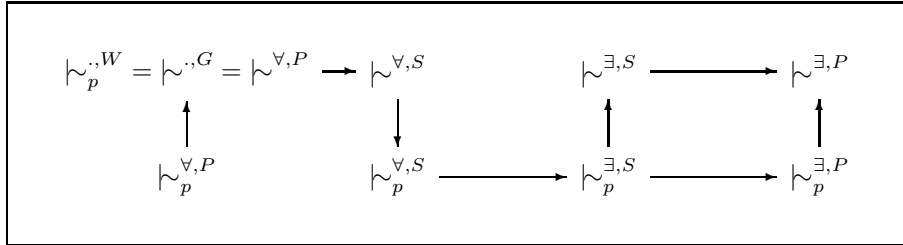

Figure 19. Cautiousness links between p -inference relations and Dung's ones in absence of stable c -extension, and in presence of a stable p -extension

As mentioned above, skeptical p -inference under the preferred semantics is the relation with the weakest inferential capacity. All p -inference relations are more cautious (i.e., they have a weaker inferential power) than the corresponding (i.e., under the same semantics) classical inference relations.

PROPOSITION 97. — Cautiousness links reported in Table 10 hold for every finite argumentation framework which has a stable extension, but no stable p -extension.

Table 10. Cautiousness links between p -inference relations and Dung's inference relations in presence of a stable extension and in absence of a stable p -extension

	$\sim_p^{\exists,P}$	$\sim_p^{\forall,P}$	$\sim_p^{\cdot,W}$
$\sim^{\exists,P}$	$\not\subseteq, \supseteq_1$	$\not\subseteq, \supseteq_2$	$\not\subseteq, \supseteq_3$
$\sim^{\exists,S}$	$\not\subseteq, \not\supseteq_4$	$\not\subseteq, \not\supseteq_5$	$\not\subseteq, \supseteq_6$
$\sim^{\forall,P}$	$\not\subseteq, \not\supseteq_7$	$\not\subseteq, \not\supseteq_8$	$\not\subseteq, \supseteq_9$
$\sim^{\forall,S}$	$\not\subseteq, \not\supseteq_{10}$	$\not\subseteq, \not\supseteq_{11}$	$\not\subseteq, \supseteq_{12}$
$\sim^{\cdot,G}$	$\not\subseteq, \not\supseteq_{13}$	$\not\subseteq, \not\supseteq_{14}$	$\not\subseteq, \supseteq_{15}$

PROOF 98. — According to Dung (Dung, 1995), the following chain of cautiousness links holds (III):

$$\sim^{\cdot,G} \subset \sim^{\forall,P} \subset \sim^{\forall,S} \subset \sim^{\exists,S} \subset \sim^{\exists,P}.$$

According to the definitions of p-inference relations, Lemma 32 on page 12 and transitivity of \subseteq , the following chain of cautiousness links holds (II):

$$\sim_p^{\forall, P} \subseteq \sim_p^{\forall, S} \subseteq \sim_p^{\exists, S} \subseteq \sim_p^{\exists, P}.$$

1) Non-inclusion comes from item 13 and (III) showing that $\sim^{\cdot, G} \subseteq \sim^{\exists, P}$. Inclusion comes from Corollary 48 on page 18.

2) Non-inclusion comes from item 14 and (III) showing that $\sim^{\cdot, G} \subseteq \sim^{\exists, P}$. Inclusion comes from Corollary 48 on page 18.

3) Non-inclusion and inclusion come from item 15 and (III) showing that $\sim^{\cdot, G} \subseteq \sim^{\exists, P}$.

4) The first non-inclusion comes from item 13 and (III) showing that $\sim^{\cdot, G} \subseteq \sim^{\exists, S}$. The second non-inclusion comes from item 5 and (II) showing that $\sim_p^{\forall, P} \subseteq \sim_p^{\exists, P}$.

5) The first non-inclusion comes from item 14 and (III) showing that $\sim^{\cdot, G} \subseteq \sim^{\exists, S}$. For the second non-inclusion, consider AF (ex. 99, Figure 20); $\{n\}$ is included into every preferred p-extension, but it is not included into a stable extension.

EXAMPLE 99. — Let $AF = \langle A, R \rangle$ with $A = \{a, b, c, d, e, i, n, u\}$ and $R = \{(b, a), (a, i), (c, b), (d, c), (e, c), (d, e), (a, d), (a, e), (i, n), (n, i), (i, u), (u, u)\}$. The digraph for AF is depicted on Figure 20.

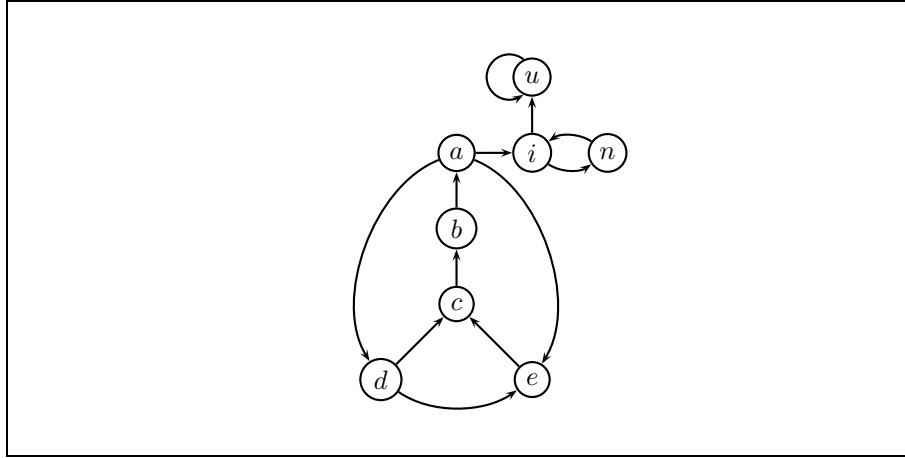

Figure 20. Example 99: The digraph for AF

$E_1 = \{a, c, n\}$, $E_2 = \{b, d, i\}$ and $E_3 = \{b, d, n\}$ are the preferred extensions of AF .

E_2 is the stable extension of AF . $E_4 = \emptyset$ is the grounded extension of AF .

E_4 is the preferred c-extension of AF . AF has no stable c-extension.

$E_1'' = \{n\}$ is the preferred p-extension of AF . E_4 is the weak p-extension of AF .

AF has no stable p-extension. \square

6) Non-inclusion and inclusion come from item 15 and (III) showing that $\sim^{\cdot, G} \subseteq \sim^{\exists, S}$.

7) The first non-inclusion comes from item 13 and (III) showing that $\sim^{\cdot,G} \subseteq \sim^{\forall,P}$. The second non-inclusion comes from item 8 and (II) showing that $\sim_p^{\forall,P} \subseteq \sim_p^{\exists,P}$.

8) The first non-inclusion comes from item 14 and (III) showing that $\sim^{\cdot,G} \subseteq \sim^{\forall,P}$. For the second non-inclusion, consider AF (ex. 99 on the preceding page, Figure 20 on the previous page); $\{n\}$ is included into every preferred p-extension, but it is not included into every preferred extension.

9) Non-inclusion and inclusion come from item 15 and (III) showing that $\sim^{\cdot,G} \subseteq \sim^{\forall,P}$.

10) The first non-inclusion comes from item 13 and (III) showing that $\sim^{\cdot,G} \subseteq \sim^{\forall,S}$. The second non-inclusion comes from item 11 and (II) showing that $\sim_p^{\forall,P} \subseteq \sim_p^{\exists,P}$.

11) The first non-inclusion comes from item 14 and (III) showing that $\sim^{\cdot,G} \subseteq \sim^{\forall,S}$. For the second non-inclusion, consider AF (ex. 99 on the preceding page, Figure 20 on the previous page); $\{n\}$ is included into every preferred p-extension, but it is not included into a stable extension.

12) Non-inclusion and inclusion come from item 15 and (III) showing that $\sim^{\cdot,G} \subseteq \sim^{\forall,S}$.

13) For the first non-inclusion, consider AF (ex. 1 on page 3, Figure 1 on page 4); $\{a, d\}$ is included into the grounded extension, but it is not included into a preferred p-extension. The second non-inclusion comes from item 14 and (II) showing that $\sim_p^{\forall,P} \subseteq \sim_p^{\exists,P}$.

14) For the first non-inclusion, $\{a, d\}$ is included in the grounded extension, but it is not included in a preferred p-extension. For the second non-inclusion, consider AF (ex. 99 on the preceding page, Figure 20 on the previous page); $\{n\}$ is included into every preferred p-extension, but it is not included into the grounded extension.

15) For the first non-inclusion, consider AF (ex. 1 on page 3, Figure 1 on page 4); $\{a, d\}$ is included into the grounded extension, but it is not included into the weak p-extension. The inclusion comes from Lemma 53 on page 19.

■

Table 4 on page 31 and Table 10 on page 42 are summarized on the Hasse diagram presented on Figure 21 on the next page.

p-inference under the weak semantics has an inferential power weaker than the ones of classical inference relations but it is not comparable w.r.t. cautiousness to skeptical p-inference under the preferred semantics.

PROPOSITION 100. — *Cautiousness links reported in Table 11 on the facing page hold for every finite argumentation framework which has no stable extension.*

PROOF 101. — According to Dung (Dung, 1995), the following chain of cautiousness links holds (III):

$$\sim^{\cdot,G} \subseteq \sim^{\forall,P} \subseteq \sim^{\forall,S} \subseteq \sim^{\exists,S} \subseteq \sim^{\exists,P}.$$

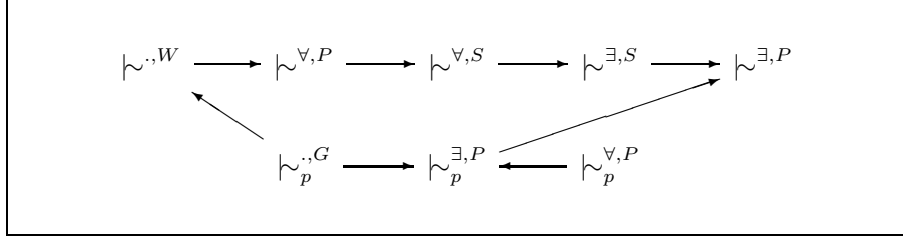

Figure 21. Cautiousness links between p -inference relations and Dung's ones in absence of stable p -extension and in presence of a stable extension

Table 11. Cautiousness links between p -inference relations and Dung's inference relations in absence of a stable extension

	$\sim_p^{\exists, P}$	$\sim_p^{\forall, P}$	$\sim_p^{\cdot, W}$
$\sim^{\exists, P}$	$\not\subseteq, \supseteq_1$	$\not\subseteq, \supseteq_2$	$\not\subseteq, \supseteq_3$
$\sim^{\forall, P}$	$\not\subseteq, \not\supseteq_4$	$\not\subseteq, \not\supseteq_5$	$\not\subseteq, \supseteq_6$
$\sim^{\cdot, G}$	$\not\subseteq, \not\supseteq_7$	$\not\subseteq, \not\supseteq_8$	$\not\subseteq, \supseteq_9$

According to the definitions of p -inference relations, Lemma 32 on page 12 and transitivity of \subseteq , the following chain of cautiousness links holds (II):

$$\sim_p^{\forall, P} \subseteq \sim_p^{\forall, S} \subseteq \sim_p^{\exists, S} \subseteq \sim_p^{\exists, P}.$$

1) Non-inclusion comes from item 7 and (III) showing that $\sim^{\cdot, G} \subseteq \sim^{\exists, P}$. Inclusion comes from Corollary 48 on page 18.

2) Non-inclusion comes from item 8 and (III) showing that $\sim^{\cdot, G} \subseteq \sim^{\exists, P}$. Inclusion comes from Corollary 48 on page 18.

3) Non-inclusion and inclusion come from item 9 and (III) showing that $\sim^{\cdot, G} \subseteq \sim^{\exists, P}$.

4) The first non-inclusion comes from item 7 and (III) showing that $\sim^{\cdot, G} \subseteq \sim^{\forall, P}$. The second non-inclusion comes from item 5 and (II) showing that $\sim_p^{\forall, P} \subseteq \sim_p^{\exists, P}$.

5) The first non-inclusion comes from item 8 and (III) showing that $\sim^{\cdot, G} \subseteq \sim^{\forall, P}$. For the second non-inclusion, consider AF (ex. 85 on page 31, Figure 13 on page 32); $\{n\}$ is included into every preferred p -extension, but it is not included into every preferred extension.

6) Non-inclusion and inclusion come from item 9 and (III) showing that $\sim^{\cdot, G} \subseteq \sim^{\forall, P}$.

7) For the first non-inclusion, consider AF (ex. 77 on page 27, Figure 9 on page 28); $\{a, d\}$ is included into the grounded extension, but it is not included into a preferred p -extension. The second non-inclusion comes from item 8 and (II) showing that $\sim_p^{\forall, P} \subseteq \sim_p^{\exists, P}$.

8) For the first non-inclusion, consider AF (ex. 77 on page 27, Figure 9 on page 28); $\{a, d\}$ is included into the grounded extension, but it is not included into a preferred p-extension. For the second non-inclusion, consider AF (ex. 85 on page 31, Figure 13 on page 32); $\{n\}$ is included into every preferred p-extension, but it is not included into the grounded extension.

9) For the non-inclusion, consider AF (ex. 77 on page 27, Figure 9 on page 28); $\{a, d\}$ is included into the grounded extension, but it is not included into the weak p-extension. Inclusion comes from Lemma 53 on page 19.

■

Table 4 on page 31 and Table 11 on the preceding page are summarized on the following Hasse diagram (Figure 22).

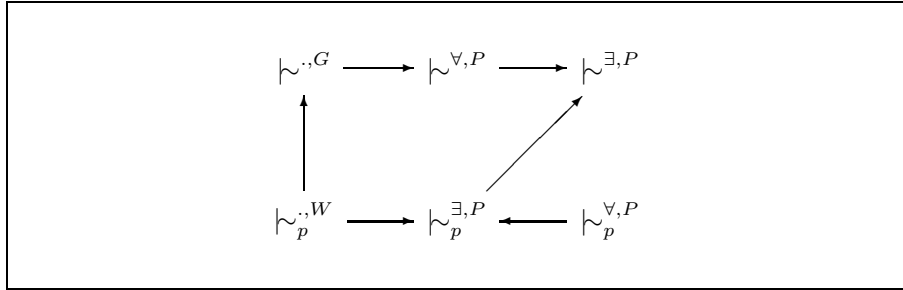

Figure 22. Cautiousness links between prudent inference relations and Dung’s ones in absence of a stable extension

5.5. Cautiousness links between c-inference relations and p-inference relations

Cautiousness links between c-inference relations and p-inference relations are summarized in the following three propositions.

PROPOSITION 102. — *Cautiousness links reported in Table 12 on the facing page hold for every finite argumentation framework which has a stable c-extension.*

PROOF 103. — According to the definitions of c-inference relations, Lemma 32 on page 12 and transitivity of \subseteq , the following chain of cautiousness links holds (I):

$$\mathcal{H}_c^{\forall, P} \subseteq \mathcal{H}_c^{\forall, S} \subseteq \mathcal{H}_c^{\exists, S} \subseteq \mathcal{H}_c^{\exists, P}.$$

According to the definitions of p-inference relations, Lemma 32 on page 12 and transitivity of \subseteq , the following chain of cautiousness links holds (II):

$$\mathcal{H}_p^{\forall, P} \subseteq \mathcal{H}_p^{\forall, S} \subseteq \mathcal{H}_p^{\exists, S} \subseteq \mathcal{H}_p^{\exists, P}.$$

1) Non-inclusion comes from item 5 and (II) showing that $\mathcal{H}_p^{\exists, S} \subseteq \mathcal{H}_p^{\exists, P}$. Inclusion comes from Corollary 48 on page 18.

Table 12. Cautiousness links between c -inference relations and p -inference relations in presence of a stable c -extension

	$\sim_c^{\exists,P}$	$\sim_c^{\exists,S}$	$\sim_c^{\forall,P}$	$\sim_c^{\forall,S}$
$\sim_p^{\exists,P}$	\subseteq, \supseteq_1	\subseteq, \supseteq_2	\subseteq, \supseteq_3	\subseteq, \supseteq_4
$\sim_p^{\exists,S}$	$\subseteq, \not\supseteq_5$	\subseteq, \supseteq_6	\subseteq, \supseteq_7	\subseteq, \supseteq_8
$\sim_p^{\forall,P}$	$\subseteq, \not\supseteq_9$	$\subseteq, \not\supseteq_{10}$	$\subseteq, ?_{11}$	$\subseteq, \not\supseteq_{12}$
$\sim_p^{\forall,S}$	$\subseteq, \not\supseteq_{13}$	$\subseteq, \not\supseteq_{14}$	$\subseteq, \supseteq_{15}$	$\subseteq, \not\supseteq_{16}$
$\sim_p^{W,P}$	$\subseteq, \not\supseteq_{17}$	$\subseteq, \not\supseteq_{18}$	$\subseteq, \supseteq_{19}$	$\subseteq, \not\supseteq_{20}$

2) Non-inclusion comes from item 6 and (II) showing that $\sim_p^{\exists,S} \subseteq \sim_p^{\exists,P}$. Inclusion comes from Proposition 45 on page 16.

3) Non-inclusion comes from item 11 and (II) showing that $\sim_p^{\forall,P} \subseteq \sim_p^{\exists,P}$. Inclusion comes from item 15 and (II) showing that $\sim_p^{\forall,S} \subseteq \sim_p^{\exists,P}$.

4) Non-inclusion comes from item 8 and (II) showing that $\sim_p^{\exists,S} \subseteq \sim_p^{\exists,P}$. Inclusion comes from Proposition 45 on page 16.

5) For the first non-inclusion, consider AF (ex. 47 on page 17, Figure 5 on page 17); $\{i, b\}$ is included into a stable p -extension, but it is not included into a preferred c -extension. For the second non-inclusion, consider AF (ex. 34 on page 12, Figure 3 on page 13); $\{a\}$ is included into a preferred c -extension, but it is not included into a stable p -extension.

6) Non-inclusion comes from item 5 and (I) showing that $\sim_c^{\exists,S} \subseteq \sim_c^{\exists,P}$. Inclusion comes from Proposition 45 on page 16.

7) Non-inclusion comes from item 11 and (II) showing that $\sim_p^{\forall,P} \subseteq \sim_p^{\exists,S}$. Inclusion comes from item 15 and (II) showing that $\sim_p^{\forall,S} \subseteq \sim_p^{\exists,S}$.

8) For the first non-inclusion, in AF (ex. 47 on page 17, Figure 5 on page 17), $\{b\}$ is included in a stable p -extension, but is not included in every stable c -extension. (I) shows that $\sim_c^{\forall,S} \subseteq \sim_c^{\exists,S}$, hence, according to Proposition 45 on page 16, we have $\sim_c^{\forall,S} \subseteq \sim_p^{\exists,S}$.

9) Inclusion comes from 13 and (II) showing that $\sim_p^{\forall,P} \subseteq \sim_p^{\forall,S}$. Non-inclusion comes from item 12 and (I) showing that $\sim_c^{\forall,S} \subseteq \sim_c^{\exists,P}$.

10) Inclusion comes from item 14 and (II) showing that $\sim_p^{\forall,P} \subseteq \sim_p^{\forall,S}$. Non-inclusion comes from item 12 and (I) showing that $\sim_c^{\forall,S} \subseteq \sim_c^{\exists,S}$.

11) For the first non-inclusion, consider AF (ex. 47 on page 17, Figure 5 on page 17); $\{i\}$ is included into every preferred p -extension, but it is not included into every preferred c -extension. We ignore whether $\sim_c^{\forall,P} \subseteq \sim_p^{\forall,P}$.

12) Inclusion comes from item 16 and (II) showing that $\sim_p^{\forall,P} \subseteq \sim_p^{\forall,S}$. For the non-inclusion, consider AF (ex. 47 on page 17, Figure 5 on page 17); $\{a\}$ is included into every stable c -extension, but it is not included into every preferred p -extension.

13) Proposition 45 on page 16 shows that $\sim_p^{\forall,S} \subseteq \sim_c^{\forall,S}$. (I) shows that $\sim_c^{\forall,S} \subseteq \sim_c^{\exists,P}$. Hence, since \subseteq is transitive, we have $\sim_p^{\forall,S} \subseteq \sim_c^{\exists,P}$. Non-inclusion comes from item 16 and (I) showing that $\sim_c^{\forall,S} \subseteq \sim_c^{\exists,P}$.

14) Proposition 45 on page 16 shows that $\sim_p^{\forall,S} \subseteq \sim_c^{\forall,S}$. (I) shows that $\sim_c^{\forall,S} \subseteq \sim_c^{\exists,S}$. Hence, since \subseteq is transitive, we have $\sim_p^{\forall,S} \subseteq \sim_c^{\exists,S}$. Non-inclusion comes from item 16 and (I) showing that $\sim_c^{\forall,S} \subseteq \sim_c^{\exists,S}$.

15) Non-inclusion comes from item 11 and (II) showing that $\sim_p^{\forall,P} \subseteq \sim_p^{\forall,S}$. Inclusion comes from item 19 and Table 3 on page 28 showing that $\sim_p^{\forall,P} \subseteq \sim_p^{\forall,S}$.

16) Inclusion comes from Proposition 45 on page 16. For non-inclusion, consider AF (ex. 47 on page 17, Figure 5 on page 17); $\{a\}$ is included into every stable c-extension, but it is not included into every stable p-extension.

17) Inclusion comes from item 13 and Table 3 on page 28 showing that $\sim_p^{\forall,W} \subseteq \sim_p^{\forall,S}$. Non-inclusion comes from item 20 and (I) showing that $\sim_c^{\forall,S} \subseteq \sim_c^{\exists,P}$.

18) Inclusion comes from item 14 and Table 3 on page 28 showing that $\sim_p^{\forall,W} \subseteq \sim_p^{\forall,S}$. Non-inclusion comes from item 20 and (I) showing that $\sim_c^{\forall,S} \subseteq \sim_c^{\exists,S}$.

19) Non-inclusion comes from item 11 and (II) showing that $\sim_p^{\forall,P} \subseteq \sim_p^{\forall,S}$. Inclusion comes from Proposition 61 on page 22.

20) Inclusion comes from item 16 and Table 3 on page 28 showing that $\sim_p^{\forall,W} \subseteq \sim_p^{\forall,S}$. For non-inclusion, consider AF_5 (ex. 47 on page 17, Figure 5 on page 17); $\{a\}$ is included into every stable c-extension, but it is not included into the weak p-extension.

■

Table 1 on page 25, Table 3 on page 28 and Table 12 on the preceding page are summarized on the Hasse diagram of Figure 23.

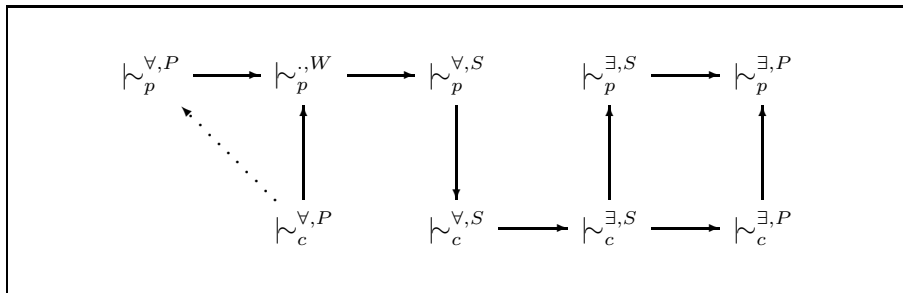

Figure 23. Cautiousness links between p-inference relations and c-inference in presence of stable c-extension

c-inference relations are typically more cautious than p-inference relations. We ignore whether $\sim_c^{\forall,P} \subseteq \sim_p^{\forall,P}$.

PROPOSITION 104. — *Cautiousness links reported in Table 13 hold for every finite argumentation framework which has a stable p-extension, but no stable c-extension.*

Table 13. *Cautiousness links between c-inference relations and p-inference relations in absence of a stable c-extension and in presence of a stable c-extension*

	$\mathfrak{h}_c^{\exists,P}$	$\mathfrak{h}_c^{\forall,P}$
$\mathfrak{h}_p^{\exists,P}$	$\not\subseteq, \supseteq_1$	$\not\subseteq, \supseteq_2$
$\mathfrak{h}_p^{\exists,S}$	$\not\subseteq, \not\supseteq_3$	$\not\subseteq, \not\supseteq_4$
$\mathfrak{h}_p^{\forall,P}$	$\not\subseteq, \not\supseteq_5$	$\not\subseteq, \not\supseteq_6$
$\mathfrak{h}_p^{\forall,S}$	$\not\subseteq, \not\supseteq_7$	$\not\subseteq, \not\supseteq_8$
$\mathfrak{h}_p^{\cdot,W}$	$\not\subseteq, \not\supseteq_9$	$\not\subseteq, \not\supseteq_{10}$

PROOF 105. — According to the definitions of c-inference relations, Lemma 32 on page 12 and transitivity of \subseteq , the following chain of cautiousness links holds (I):

$$\mathfrak{h}_c^{\forall,P} \subseteq \mathfrak{h}_c^{\forall,S} \subseteq \mathfrak{h}_c^{\exists,S} \subseteq \mathfrak{h}_c^{\exists,P}.$$

According to the definitions of p-inference relations, Lemma 32 on page 12 and transitivity of \subseteq , the following chain of cautiousness links holds (II):

$$\mathfrak{h}_p^{\forall,P} \subseteq \mathfrak{h}_p^{\forall,S} \subseteq \mathfrak{h}_p^{\exists,S} \subseteq \mathfrak{h}_p^{\exists,P}.$$

1) Non-inclusion comes from item 5 and (II) showing that $\mathfrak{h}_p^{\forall,P} \subseteq \mathfrak{h}_p^{\exists,P}$. Inclusion comes from Corollary 48 on page 18.

2) Non-inclusion comes from item 6 and (II) showing that $\mathfrak{h}_p^{\forall,P} \subseteq \mathfrak{h}_p^{\exists,P}$. Inclusion comes from Corollary 48 on page 18.

3) The first non-inclusion comes from item 5 and (II) showing that $\mathfrak{h}_p^{\forall,P} \subseteq \mathfrak{h}_p^{\exists,S}$. The second non-inclusion comes from item 4 and (I) showing that $\mathfrak{h}_c^{\forall,P} \subseteq \mathfrak{h}_c^{\exists,P}$.

4) The first non-inclusion comes from item 6 and (II) showing that $\mathfrak{h}_p^{\forall,P} \subseteq \mathfrak{h}_p^{\exists,S}$. For the second non-inclusion, consider AF (ex. 90 on page 35, Figure 15 on page 35); $\{n\}$ is included into every preferred c-extension, but it is not included into a stable p-extension.

5) For first non-inclusion, consider AF (ex. 76 on page 27, Figure 8 on page 27); $\{i\}$ is included into every preferred p-extension, but it is not included in a preferred c-extension. The second non-inclusion comes from item 6 and (I) showing that $\mathfrak{h}_c^{\forall,P} \subseteq \mathfrak{h}_c^{\exists,P}$.

6) For the first non-inclusion, consider AF (ex. 76 on page 27, Figure 8 on page 27); $\{i\}$ is included into every preferred p-extension, but it is not included into a preferred c-extension. For the second non-inclusion, consider AF (ex. 90 on page 35, Figure 15 on page 35); $\{n\}$ is included into every preferred c-extension, but it is not included into every preferred p-extension.

7) The first non-inclusion comes from item 5 and (II) showing that $\sim_p^{\forall,P} \subseteq \sim_p^{\forall,S}$. The second non-inclusion comes from item 8 and (I) showing that $\sim_c^{\forall,P} \subseteq \sim_c^{\exists,P}$.

8) The first non-inclusion comes from item 6 and (II) showing that $\sim_p^{\forall,P} \subseteq \sim_p^{\forall,S}$. For the second non-inclusion, consider AF (ex. 90 on page 35, Figure 15 on page 35); $\{n\}$ is included into every preferred c-extension, but it is not included into every stable p-extension.

9) The first non-inclusion comes from item 5 and Table 3 on page 28 showing that $\sim_p^{\forall,P} \subseteq \sim_p^{\cdot,W}$. The second non-inclusion comes from item 10. and (I) showing that $\sim_c^{\forall,P} \subseteq \sim_c^{\exists,P}$.

10) The first non-inclusion comes from item 6 and Table 3 on page 28 showing that $\sim_p^{\forall,P} \subseteq \sim_p^{\cdot,W}$. For the second non-inclusion, consider AF (ex. 90 on page 35, Figure 15 on page 35); $\{n\}$ is included into every preferred c-extension, but it is not included into the weak p-extension.

■

Table 2 on page 26, Table 3 on page 28 and Table 13 on the previous page are summarized on the following Hasse diagram (see Figure 24).

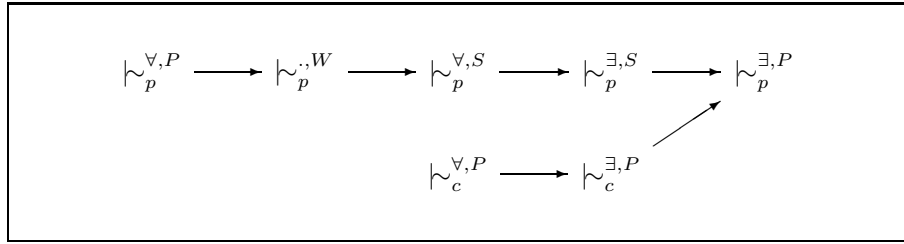

Figure 24. Cautiousness links between p-inference relations and c-inference relation in absence of a stable c-extension and in presence of stable p-extension

The set of arguments which may be inferred using any c-inference relation is included into the set derivable using the credulous p-inference relation under the preferred semantics. All other p-inference relations are not comparable with c-inference relations.

PROPOSITION 106. — Cautiousness links reported in Table 14 on the next page hold for every finite argumentation framework which has no stable p-extension.

PROOF 107. — According to the definitions of c-inference relations, Lemma 32 on page 12 and transitivity of \subseteq , the following chain of cautiousness links holds (I):

$$\sim_c^{\forall,P} \subseteq \sim_c^{\forall,S} \subseteq \sim_c^{\exists,S} \subseteq \sim_c^{\exists,P}.$$

According to the definitions of p-inference relations, Lemma 32 on page 12 and transitivity of \subseteq , the following chain of cautiousness links holds (II):

$$\sim_p^{\forall,P} \subseteq \sim_p^{\forall,S} \subseteq \sim_p^{\exists,S} \subseteq \sim_p^{\exists,P}.$$

Table 14. Cautiousness links between c-inference relations and p-inference relations in absence of a stable p-extension

	$\sim_c^{\exists, P}$	$\sim_c^{\forall, P}$
$\sim_p^{\exists, P}$	$\not\subseteq, \supseteq_1$	$\not\subseteq, \supseteq_2$
$\sim_p^{\forall, P}$	$\not\subseteq, \not\supseteq_3$	$\not\subseteq, \not\supseteq_4$
$\sim_p^{W, P}$	$\not\subseteq, \not\supseteq_5$	$\not\subseteq, \not\supseteq_6$

In items a) AF has a stable extension (but no stable p-extension). In items b) AF has no stable extension.

1) Non-inclusion comes from item 3 and (II) showing $\sim_p^{\forall, P} \subseteq \sim_p^{\exists, P}$. Inclusion comes from Corollary 48 on page 18.

2) Non-inclusion comes from item 4 and (II) showing that $\sim_p^{\forall, P} \subseteq \sim_p^{\exists, P}$. Inclusion comes from Corollary 48 on page 18.

3) a) For the first non-inclusion, consider AF (ex. 108, Figure 25); $\{d, n\}$ is included into every preferred p-extension, but it is not included into a preferred c-extension.

EXAMPLE 108. — Let $AF = \langle A, R \rangle$ with $A = \{a, b, c, d, e, n, i, r, s\}$ and $R = \{(b, a), (c, a), (n, c), (d, b), (i, b), (e, c), (i, e), (d, r), (r, s), (n, s)\}$. The digraph for AF is depicted on Figure 25. $E_1 = \{i, a, d, n\}$ is the unique preferred extension, the

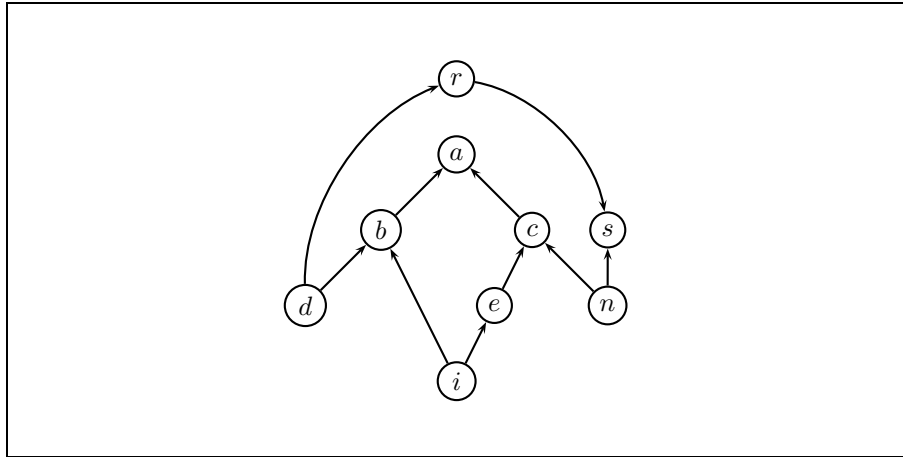

Figure 25. Example 108: The digraph for AF

unique stable extension and the grounded extension of AF . $E_1' = \{d\}$ and $E_2' = \{n\}$ are the preferred c-extensions of AF . AF has no stable c-extension. $E_1'' = \{d, i, n\}$ and $E_2'' = \{d, a, n\}$ are the preferred p-extensions of AF . E_1'' is the weak p-extension of AF . AF has no stable p-extension. \square

b) For the first non-inclusion, consider AF (ex. 109, Figure 26), $\{d, n\}$ is included into every preferred p-extension, but it is not included into a preferred c-extension.

EXAMPLE 109. — Let $AF = \langle A, R \rangle$ with $A = \{a, b, c, d, e, n, i, r, s, o\}$ and $R = \{(b, a), (c, a), (n, c), (d, b), (i, b), (e, c), (i, e), (d, r), (r, s), (n, s), (o, o)\}$. The digraph for AF is depicted on Figure 26.

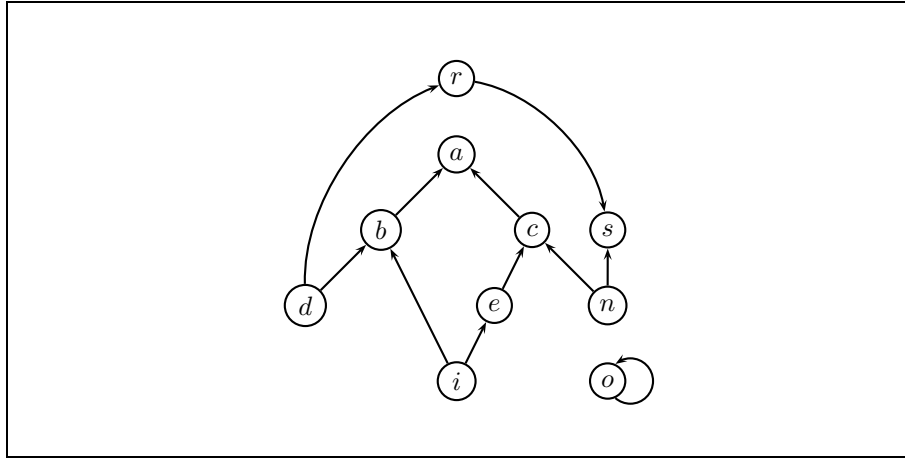

Figure 26. Example 109: The digraph for AF

$E_1 = \{i, a, d, n\}$ is the unique preferred extension and the grounded extension of AF . AF has no stable extension. $E'_1 = \{d\}$ and $E'_2 = \{n\}$ are the preferred c-extensions of AF . AF has no stable c-extension. $E''_1 = \{d, i, n\}$ and $E''_2 = \{d, a, n\}$ are the preferred p-extensions of AF . E''_1 is the weak p-extension of AF . AF has no stable p-extension. \square

The second non-inclusion comes from item 4 and (I) showing that $\vdash_c^{\forall, P} \subseteq \vdash_c^{\exists, P}$.

4) a) For the first non-inclusion, consider AF (ex. 108 on the preceding page, Figure 25 on the previous page); $\{d, n\}$ is included into every preferred p-extension, but it is not included into every preferred c-extension. For the second non-inclusion, consider AF (ex. 110, Figure 27 on the next page); $\{a\}$ is included into every preferred c-extension, but it is not included into every preferred p-extension.

EXAMPLE 110. — Let $AF = \langle A, R \rangle$ with $A = \{a, b, c, d, e, n, i\}$ and $R = \{(b, a), (c, a), (n, c), (d, b), (i, b), (e, c), (i, e)\}$. The digraph for AF is depicted on Figure 27 on the facing page.

$E_1 = \{i, a, d, n\}$ is the unique preferred extension, the unique stable extension and the grounded extension of AF . $E'_1 = \{d, a, n\}$ is the unique preferred c-extension of AF . AF has no stable c-extension. $E''_1 = \{d, i, n\}$ and $E''_2 = \{d, a, n\}$ are the preferred p-extensions of AF . E''_1 is the weak p-extension faible of AF . AF has no stable p-extension. \square

b) For the first non-inclusion, consider AF (ex. 109, Figure 26); $\{d, n\}$ is included into every preferred p-extension, but it is not included into every preferred

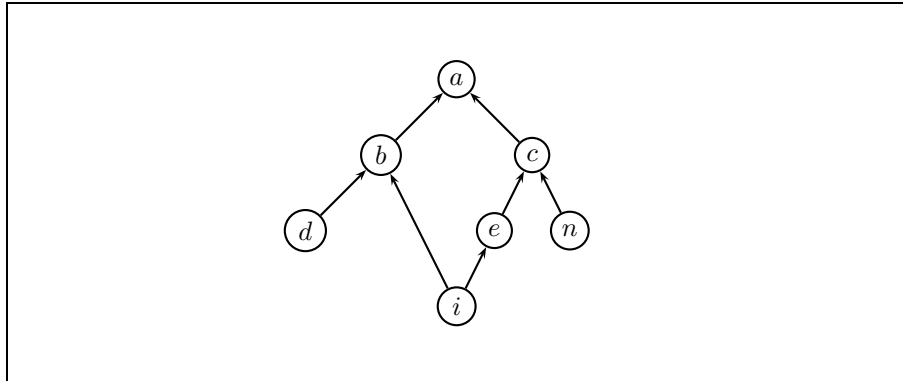

Figure 27. Example 110: The digraph for AF

c-extension. For the second non-inclusion, consider AF (ex. 111, Figure 28); $\{a\}$ is included into every preferred c-extension, but it is not included into every preferred p-extension.

EXAMPLE 111. — Let $AF = \langle A, R \rangle$ with $A = \{a, b, c, d, e, n, i, v\}$ and $R = \{(b, a), (c, a), (n, c), (d, b), (i, b), (e, c), (i, e), (v, c), (v, v)\}$. The digraph for AF is depicted on Figure 28.

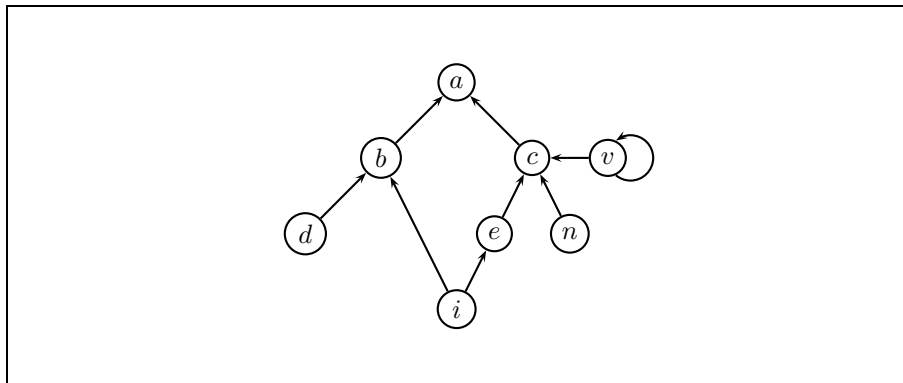

Figure 28. Example 111: The digraph for AF

$E_1 = \{i, a, d, n\}$ is the preferred extension and the grounded extension of AF . AF has no stable extension. $E'_1 = \{d, a, n\}$ is the unique preferred c-extension of AF . AF has no stable c-extension. $E''_1 = \{d, i, n\}$ and $E''_2 = \{d, a, n\}$ are the preferred p-extensions of AF . E''_1 is the weak p-extension of AF . AF has no stable p-extension. \square

5) a) For the first non-inclusion, consider AF (ex. 110 on the facing page, Figure 27); $\{i\}$ is included into the weak p-extension, but it is not included into a preferred c-extension.

b) For the first non-inclusion, consider AF (ex. 111 on the preceding page, Figure 28 on the previous page); $\{i\}$ is included into the weak p-extension, but it is not included into a preferred c-extension. The second non-inclusion comes from item 6 and (I) showing that $\sim_c^{\forall,P} \subseteq \sim_c^{\exists,P}$.

6) a) For the first non-inclusion, consider AF (ex. 110 on page 52, Figure 27 on the previous page); $\{i\}$ is included into the weak p-extension, but it is not included into a preferred c-extension. For the second non-inclusion, consider AF (ex. 110 on page 52, Figure 27 on the previous page); $\{a\}$ is included into every preferred c-extension, but it is not included into the weak p-extension.

b) For the first non-inclusion, consider AF (ex. 111 on the preceding page, Figure 28 on the previous page); $\{i\}$ is included into the weak p-extension, but it is not included into a preferred c-extension. For the second non-inclusion, consider AF (ex. 111 on the preceding page, Figure 28 on the previous page); $\{a\}$ is included into every preferred c-extension, but it is not included into the weak p-extension.

■

Table 2 on page 26, Table 4 on page 31 and Table 14 on page 51 are summarized on the following Hasse diagram (Figure 29).

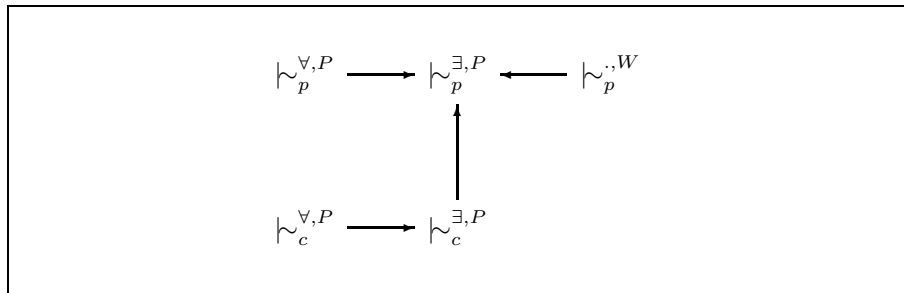

Figure 29. Cautiousness links between p-inference relations and c-inference relation in absence of a stable p-extension

Whether a stable extension exists or not, the cautiousness links between c-inference relations and p-inference relations remain identical.

6. Some complexity results

Before concluding the paper, let us consider some complexity issues. Complexity issues for Dung’s theory have been considered in (Dimopoulos *et al.*, 1996; Dunne *et al.*, 2002). For the ideal and the semi-stable semantics, complexity results can be found in (Dunne, 2008; Dunne *et al.*, 2008).

We have shown in a previous paper (Coste-Marquis *et al.*, 2005c) that considering sets of arguments (instead of single arguments) as input queries for the inference

problem does not lead to a complexity shift when Dung's inference relations are considered (the purpose is to determine whether such sets are derivable from a given finite argumentation framework AF). As to the c-inference relations and the p-inference relations, the same conclusion can be drawn.

From now on, we assume the reader acquainted with basic notions of complexity theory, especially the complexity classes P , NP , $coNP$ and the polynomial hierarchy (see e.g., (Papadimitriou, 1994)).

PROPOSITION 112. — *Let $AF = \langle A, R \rangle$ be a finite argumentation framework and $S \subseteq A$. The results of complexity reported in Table 15 hold.*

Table 15. *Decision problems in finite argumentation systems and their complexity.*

Decision question	Complexity
Is S without indirect conflict?	in P
Is S controversy-free?	in P
Is S p-admissible (resp. c-admissible)?	in P
Is S the weak p-extension?	in P
Is S included in the weak p-extension?	in P
Is S a stable p-extension (resp. stable c-extension)?	in P
Has AF a stable p-extension (resp. stable c-extension)	in NP
Is S included in a stable p-extension (resp. stable c-extension)?	in NP
Is S included in every stable p-extension (resp. stable c-extension)?	in $coNP$
Is S a preferred p-extension (resp. preferred c-extension)?	in $coNP$
Is S included in a preferred p-extension?	in NP
Is S included in a preferred c-extension?	NP -complete
Is S included in every preferred p-extension (resp. preferred c-extension)?	in Π_2^P

PROOF 113. — First of all, it is easy to show that, given a finite argumentation framework AF , deciding whether a given argument indirectly attacks (resp. indirectly defends) a given argument is in P and deciding whether a set of arguments is without indirect conflict is in P^5 and deciding whether a set of arguments is controversy-free is in P .

Accordingly, deciding whether a given set of arguments is p-admissible (resp. c-admissible) for AF is in P .

5. It has been proved that determining the existence of a simple even-length path between two given vertices in a graph is NP -complete (LaPaugh *et al.*, 1984). However, in our case, we do not require for the path to be a simple one.

As a consequence, deciding whether a given set of argument is (resp. is included in) the weak p-extension is in \mathbf{P} as well.

Furthermore, deciding whether a given set of arguments is a stable p-extension (resp. stable c-extension) of AF is in \mathbf{P} as well.

So deciding whether AF has a stable p-extension (resp. a stable c-extension) is in \mathbf{NP} : it is sufficient to guess a set $S \subseteq A$ and to check in polynomial time that S is a stable p-extension (resp. a stable c-extension). Therefore, deciding whether a given set of arguments S is included in a stable p-extension (resp. a stable c-extension) of AF is in \mathbf{NP} : it is sufficient to guess a set $E \subseteq A$ and to check in polynomial time that E is a stable p-extension (resp. a stable c-extension) of AF and that S is included in E .

Furthermore, deciding whether a given set of arguments S is included in every stable p-extension (resp. every stable c-extension) of AF is in \mathbf{coNP} : in order to show that the complementary problem is in \mathbf{NP} , it is sufficient to guess a set $E \subseteq A$ and to check in polynomial time that E is a stable p-extension (resp. a stable c-extension) of AF and that S is not included in E .

Besides, deciding whether a set of arguments S is a preferred p-extension (resp. a preferred c-extension) of AF is in \mathbf{coNP} : in order to show that the complementary problem is in \mathbf{NP} , it is sufficient to guess a proper superset S' of S and to check in polynomial time that S' is p-admissible (resp. c-admissible) for AF .

As a consequence, deciding whether a given set of arguments S is included in every preferred p-extension (resp. preferred c-extension) of AF is in Π_2^p (in order to show that the complementary problem is in Σ_2^p , it is sufficient to guess a set $E \subseteq A$ and to check in polynomial time using an \mathbf{NP} oracle that E is a preferred p-extension (resp. a preferred c-extension) for AF and that S is not included in E).

Finally, deciding whether a given set of arguments is included in a preferred p-extension (resp. a preferred c-extension) of AF is in \mathbf{NP} .

The hardness result of the problem consisting in deciding whether a given set of arguments is included in a preferred c-extension of AF comes from a polynomial reduction from 3-SAT.

Let ϕ be a CNF formula with $\phi = \bigwedge_{i=1..n} C_i$ where $C_i = \bigvee_{j=1..3} c_{i,j}$ such that no C_i is a tautology. We note C the set of clauses of ϕ and L the set of literals of ϕ .

$f : \phi \mapsto \langle AF = \langle A, R \rangle, S \rangle$ such that:

- A has 3 nodes n_i, a_i and d_i for each positive literal of L (n_i denotes the positive literal associated to the variable x_i of ϕ), one node n'_i for each negative literal of L (n'_i denotes the negative literal associated to x_i), one node C_i for each clause of C , one node T ;
- R is built in polynomial time from ϕ in the following way:
 - a) $\forall n_i \in A, (n_i, a_i) \in R, (a_i, d_i) \in R,$

- b) $\forall n'_i \in A, (n'_i, d_i) \in R,$
- c) $\forall l \in L, C_i \in C, \text{ if } l \text{ is in } C_i, (l, C_i) \in R,$
- d) $\forall C_i \in C, (C_i, T) \in R,$
- $S = \{T\}$

As a matter of illustration, the digraph associated to the formula $(a \vee b \vee c) \wedge (a \vee \neg b \vee \neg c) \wedge (\neg a \vee \neg b \vee c)$ is depicted on Figure 30. n_1 (resp. n_2, n_3) is associated to a (resp. b, c).

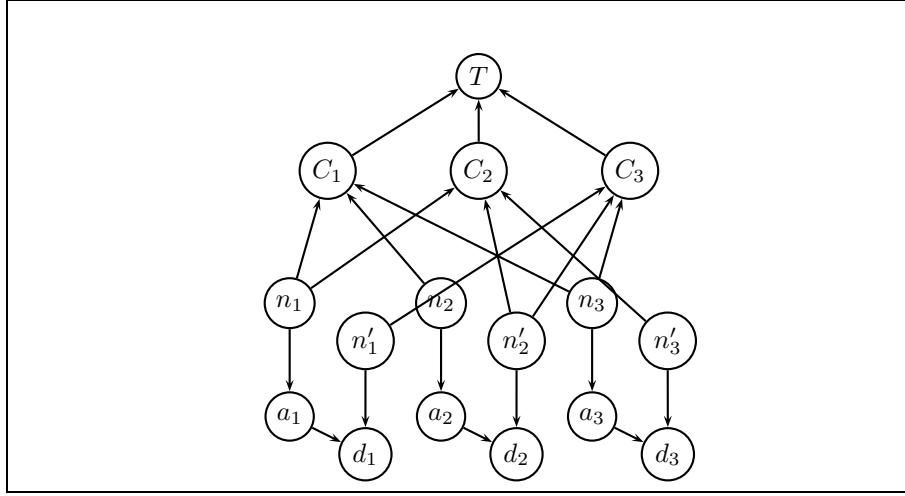

Figure 30. $(a \vee b \vee c) \wedge (a \vee \neg b \vee \neg c) \wedge (\neg a \vee \neg b \vee c)$

a_i and d_i forbid n_i and n'_i to belong to the same c -admissible set since (n'_i, n_i) is super-controversial w.r.t. d_i . T belongs to a preferred c -extension of AF if and only if T is defended against each C_i , i.e., if one of n_i or n'_i which attacks C_i belongs to the preferred c -extension too. Hence T belongs to a c -admissible set (therefore to a preferred c -extension) if and only if ϕ is satisfiable.

Since 3-SAT is NP-hard, deciding whether S is included in a preferred c -extension is NP-hard. ■

The membership results shown above are similar to the ones obtained for the classical inference relations (Dimopoulos *et al.*, 1996; Dunne *et al.*, 2002). Even if c -inference and p -inference relations are more cautious than classical inference relations, the proposed refinements do not induce a computational extra-cost.

7. Conclusion

We have presented two new semantics within Dung's theory of argumentation: prudent and careful semantics.

Prudent semantics does not allow two arguments to belong to the same extension whenever one of them attacks indirectly the other one. Controversial arguments are then handled more cautiously than with Dung's semantics.

Under the careful semantics, two arguments cannot belong to the same extension whenever one of them indirectly attacks a third one while the other argument defends it. Careful semantics always rejects controversial arguments. This behaviour is interesting for scenarios where controversies are considered as contradictions and are not desirable.

These two new semantics handle controversial arguments in different ways, yet in a more prudent way than Dung's semantics. p-extensions strengthen the notion of coherence within an extension while c-extensions strengthen it towards arguments outside the extension. Such extensions do not verify all properties verified by Dung's extensions. However, for a given family (c-extensions or p-extensions), links between the different kinds of extensions (preferred, stable, grounded, ...) are similar to the one existing between Dung's extensions. The existence of a stable p-extension or a stable c-extension for an argumentation framework still has an influence on its very nature. For instance, if there exists a stable c-extension for an argumentation framework, then it is coherent. If there exists a stable p-extension, it is relatively grounded.

We have compared w.r.t. cautiousness in a systematic and exhaustive way the derived inference relations one another and also with the ones obtained from Dung's semantics. We have shown that our relations are more cautious than the ones proposed by Dung. However, our semantics do not always agree with the grounded extension (they are sometimes more cautious).

We have also proved that the decision problems for the new inference relations we have introduced are not more complex than the corresponding ones for the inference relations based on Dung's semantics.

Note finally that both p-extensions and c-extensions can be characterized within the setting of constrained argumentation frameworks (Coste-Marquis *et al.*, 2006). Interestingly, for such frameworks, dialectical proofs can be used for generating extensions (Devred *et al.*, 2007), hence for deciding the corresponding inference relations.

Perspectives for further research includes the identification of missing complexity results (hardness ones) as well as the few missing cautiousness results.

Acknowledgements

The authors want to thank the anonymous referee for its careful reading.

8. References

- Amgoud L., Cayrol C., “Inferring from Inconsistency in Preference-Based Argumentation Frameworks”, *Journal of Automated Reasoning*, vol. 29, pp. 125–169, 2002.
- Baroni P., Giacomin M., “Solving Semantic Problems with Odd-Length Cycles in Argumentation”, *Proceedings of the 7th European Conference on Symbolic and Quantitative Approaches to Reasoning with Uncertainty*, vol. 2711 of *Lecture Notes on Artificial Intelligence*, pp. 440–451, 2003.
- Baroni P., Giacomin M., “A recursive approach to argumentation: motivation and perspectives”, *Proceedings of the 10th International Workshop on Non-Monotonic Reasoning*, pp. 50–58, 2004.
- Baroni P., Giacomin M., Guida G., “Extending abstract argumentation systems theory”, *Artificial Intelligence*, vol. 120, num. 2, pp. 251–270, 2000.
- Baroni P., Giacomin M., Guida G., “SCC-recursiveness: a general schema for argumentation semantics”, *Artificial Intelligence*, vol. 168, pp. 162–210, 2005.
- Besnard P., Hunter A., “A logic-based theory of deductive arguments”, *Artificial Intelligence*, vol. 128, pp. 203–235, 2001.
- Besnard P., Hunter A., *Elements of Argumentation*, MIT Press, 2008.
- Caminada M., “Semi-stable semantics”, *Proceedings of the 1st International Conference on Computational Models of Argument*, pp. 121–130, 2006.
- Cayrol C., Lagasque-Schiex M., “On the acceptability of arguments in bipolar argumentation framework”, *Proceedings of the 8th European Conference on Symbolic and Quantitative Approaches to Reasoning with Uncertainty*, pp. 378–389, 2005.
- Coste-Marquis S., Devred C., Marquis P., “Inference from controversial arguments”, *Proceedings of the 12th International Conference on Logic for Programming, Artificial Intelligence and Reasoning*, pp. 606–620, 2005a.
- Coste-Marquis S., Devred C., Marquis P., “Prudent Semantics for Argumentation Frameworks”, *Proceedings of the 17th International Conference on Tools with Artificial Intelligence*, pp. 568–572, 2005b.
- Coste-Marquis S., Devred C., Marquis P., “Symmetric Argumentation Frameworks”, *Proceedings of the 8th European Conference on Symbolic and Quantitative Approaches to Reasoning with Uncertainty*, pp. 317–328, 2005c.
- Coste-Marquis S., Devred C., Marquis P., “Constrained Argumentation Frameworks”, *Proceedings of the 10th International Conference on Principles of Knowledge Representation and Reasoning*, Lake District (UK), pp. 112–122, 2006.
- Devred C., Doutre S., “Dialectical Proof Theories for the Credulous Prudent Preferred Semantics of Argumentation”, *Proceedings of the 9th European Conference on Symbolic and Quantitative Approaches to Reasoning with Uncertainty*, pp. 271–282, 2007.
- Dimopoulos Y., Nebel B., Toni F., “On the Computational Complexity of Assumption-based Argumentation for Default Reasoning”, *Artificial Intelligence*, vol. 141, pp. 57–78, 2002.

Dimopoulos Y., Torres A., “Graph theoretical structures in logic programs and default theories”, *Theoretical Computer Science*, vol. 170, pp. 209–244, 1996.

Doutre S., *Autour de la sémantique préférée des systèmes d’argumentation*, Thèse de doctorat d’université, Université Paul Sabatier, Toulouse, 2002.

Dung P. M., “On the Acceptability of Arguments and its Fundamental Role in Nonmonotonic Reasoning, Logic Programming and n-Person Games”, *Artificial Intelligence*, vol. 77, num. 2, pp. 321–358, 1995.

Dung P. M., Mancarella P., Toni F., “Computing ideal semantics argumentation”, *Artificial Intelligence*, vol. 171, pp. 642–674, 2007.

Dunne P., “The Computational Complexity of Ideal Semantics I: Abstract argumentation Frameworks”, *Proceedings of the 2nd International Conference on Computational Models of Argument*, pp. 147–158, 2008.

Dunne P., Bench-Capon T., “Coherence in finite argument system”, *Artificial Intelligence*, vol. 141, pp. 187–203, 2002.

Dunne P., Caminada M., “Computational Complexity of Semi-stable Semantics in Abstract Argumentation Framework”, *Proceedings of the 11th European Conference on Logics in Artificial Intelligence*, pp. 153–165, 2008.

Elvang-Gøransson M., Hunter A., “Argumentative logics: Reasoning with classically inconsistent information”, *Data and Knowledge Engineering*, vol. 16, pp. 125–145, 1995.

Elvang-Gøransson M., Fox J., Krause P., “Acceptability of arguments as logical uncertainty”, *Proceedings of the European Conference on Symbolic and Quantitative Approaches to Reasoning and Uncertainty*, pp. 85–90, 1993.

LaPaugh A., Papadimitriou C., “The even-path problem for graphs and digraphs”, *Networks*, vol. 14, pp. 507–513, 1984.

Mardi M., Cayrol C., Lagasque-Schiex M.-C., *Bipolarité en argumentation : acceptabilité et algorithmes*, Rapport interne irit, IRIT, Université Paul Sabatier, Toulouse, France, 2005.

Papadimitriou C., *Computational complexity*, Addison-Wesley, 1994.

Pollock J., “How to Reason Defeasibly”, *Artificial Intelligence*, vol. 57, num. 1, pp. 1–42, 1992.

Prakken A., Vreeswijk G., “Logics for defeasible argumentation”, in D. Gabbay, F. Guenther (eds), *Handbook of Philosophical Logic, Second edition*, vol. 4, Kluwer Academic Publishers, pp. 219–318, 2002.

Simari G., Loui R., “A mathematical treatment of defeasible reasoning and its implementation”, *Artificial Intelligence*, vol. 53, num. 2–3, pp. 125–157, 1992.

Toulmin S., *The Uses of Argument*, Cambridge University Press, 1958.

List of Tables

1 Cautiousness links between c-inference relations in presence of a stable c-extension 25

2	Cautiousness links between c-inference relations in absence of a stable c-extension	26
3	Cautiousness links between p-inference relations in presence of a stable p-extension	28
4	Cautiousness links between p-inference relations in absence of a stable p-extension	31
5	Cautiousness links between c-inference relations and Dung's inference relations in presence of a stable c-extension	33
6	Cautiousness links between c-inference relations and Dung's inference relations in presence of a stable extension and in absence of a stable c-extension	34
7	Cautiousness links between c-inference relations and Dung's inference relations in absence of a stable extension	37
8	Cautiousness links between p-inference relations and Dung's inference relations in presence of a stable c-extension	39
9	Cautiousness links between p-inference relations and Dung's inference relations in presence of a stable p-extension and in absence of a stable c-extension	40
10	Cautiousness links between p-inference relations and Dung's inference relations in presence of a stable extension and in absence of a stable p-extension	42
11	Cautiousness links between p-inference relations and Dung's inference relations in absence of a stable extension	45
12	Cautiousness links between c-inference relations and p-inference relations in presence of a stable c-extension	47
13	Cautiousness links between c-inference relations and p-inference relations in absence of a stable c-extension and in presence of a stable c-extension	49
14	Cautiousness links between c-inference relations and p-inference relations in absence of a stable p-extension	51
15	Decision problems in finite argumentation systems and their complexity.	55

List of Figures

1	Example 1: The digraph for AF	4
2	Example 2: The digraph for AF	4
3	Example 34: The digraph of AF	13

4	Example 44: The digraph for AF	16
5	Example 47: The digraph for AF	17
6	Example 50: The digraph of AF	19
7	Example 73: The digraph for AF	26
8	Example 76: The digraph for AF	27
9	Example 77: The digraph for AF	28
10	Example 80: The digraph for AF	29
11	Example 81: The digraph for AF	30
12	Example 84: The digraph for AF	31
13	Example 85: The digraph for AF	32
14	Cautiousness links between c-inference relations and Dung's ones in presence of a stable c-extension	34
15	Example 90: The digraph for AF	35
16	Cautiousness links between careful inference relations and Dung's ones in presence of stable extension and in absence of preferred c-extension	37
17	Cautiousness links between careful inference relations and Dung's ones in absence of stable extension	38
18	Cautiousness links between p-inference relations and Dung's ones in presence of stable c-extension	40
19	Cautiousness links between p-inference relations and Dung's ones in absence of stable c-extension, and in presence of a stable p-extension	42
20	Example 99: The digraph for AF	43
21	Cautiousness links between p-inference relations and Dung's ones in absence of stable p-extension and in presence of a stable extension	45
22	Cautiousness links between prudent inference relations and Dung's ones in absence of a stable extension	46
23	Cautiousness links between p-inference relations and c-inference in presence of stable c-extension	48
24	Cautiousness links between p-inference relations and c-inference relation in absence of a stable c-extension and in presence of stable p-extension	50
25	Example 108: The digraph for AF	51
26	Example 109: The digraph for AF	52

27	Example 110: The digraph for AF	53
28	Example 111: The digraph for AF	53
29	Cautiousness links between p-inference relations and c-inference relation in absence of a stable p-extension	54
30	$(a \vee b \vee c) \wedge (a \vee \neg b \vee \neg c) \wedge (\neg a \vee \neg b \vee c)$	57