

On the Merging of Dung's Argumentation Systems

Sylvie Coste-Marquis^a, Caroline Devred^a,
Sébastien Konieczny^a, Marie-Christine Lagasquie-Schiex^b,
Pierre Marquis^a

^a*CRIL-CNRS, Université d'Artois, Lens, France*

^b*IRIT-CNRS, UPS, Toulouse, France*

Abstract

In this paper, the problem of deriving sensible information from a collection of argumentation systems coming from different agents is addressed. The underlying argumentation theory is Dung's one: each argumentation system gives both a set of arguments and the way they interact (*i.e.*, attack or non-attack) according to the corresponding agent. The inadequacy of the simple, yet appealing, method which consists in voting on the agents' selected extensions calls for a new approach. To this purpose, a general framework for merging argumentation systems from Dung's theory of argumentation is presented. The objective is achieved through a three-step process: first, each argumentation system is expanded into a partial system over the set of all arguments considered by the group of agents (reflecting that some agents may easily ignore arguments pointed out by other agents, as well as how such arguments interact with her own ones); then, merging is used on the expanded systems as a way to solve the possible conflicts between them, and a set of argumentation systems which are as close as possible to the whole profile is generated; finally, voting is used on the selected extensions of the resulting systems so as to characterize the acceptable arguments at the group level.

Key words: Argumentation frameworks, Argument in agent system

1 Introduction

Argumentation is based on the exchange and the evaluation of interacting arguments which may represent information of various kinds, especially beliefs

* This paper is an extended and revised version of a paper entitled "Merging Argumentation Systems" that appeared in the Proceedings of AAI'05, pages 614–619.

or goals. Argumentation can be used for modelling some aspects of reasoning, decision making, and dialogue; as such, it has been applied to several domains, including law. For instance, when an agent has conflicting beliefs (viewed as arguments), a (nontrivial) set of plausible consequences can be derived through argumentation from the most acceptable arguments for the agent (additional information like a plausibility ordering are often taken into account in the evaluation phase). Much work has been devoted to this reasoning issue (see for example (13; 21; 26; 25; 1; 27)).

Several theories of argumentation exist; many of them make explicit the nature of arguments, the way arguments are generated, how they interact and how to evaluate them, and finally a characterization of the most acceptable arguments. A key issue is the interaction between arguments which is typically based on a notion of attack; for example, when an argument takes the form of a logical proof, arguments for a statement and arguments against it can be put forward. In that case, the attack relation relies on logical inconsistency.

Dung's theory of argumentation includes several formal systems developed so far for commonsense reasoning or logic programming (13). It is abstract enough to manage without any assumptions on the nature of arguments or the attack relation. Indeed, an argumentation system *à la* Dung consists of a set of (abstract) arguments, together with a binary relation on it (the attack relation). Several semantics can be used for defining interesting sets of arguments (so-called extensions) from which acceptable sets of arguments (*i.e.*, the derivable sets) can be characterized.

In a multi-agent setting, argumentation can also be used to represent (part of) some information exchange processes, like negotiation, or persuasion (see for example (22; 28; 18; 24; 3; 4; 5)). For instance, a negotiation process between two agents about whether some belief must be considered as true given some evidence can be modelled as a two-player game where each move consists in reporting an argument which attacks arguments given by the opponent.

In this paper, we also consider argumentation in a multi-agent setting, but from a very different perspective. Basically, our purpose is to characterize the set of arguments acceptable by a group of agents, when the data furnished by each agent consist solely of an (abstract) argumentation system from Dung's theory.

At a first glance, a simple approach for achieving this goal consists in voting on the acceptable sets provided by each agent: a set of arguments is considered acceptable by the group if and only if it is acceptable for "sufficiently many" agents from the group (where the meaning of "sufficiently many" refers to different *voting* methods). No merging at all is required here. By means of example, we show that our merging-based approach leads to results which are

much more expected than those furnished by a direct vote on the (sets of) arguments acceptable by each agent.

Our approach is more sophisticated. It follows a three-step process: first, each argumentation system is expanded into a partial system over the set of all arguments considered by the group of agents (reflecting that some agents may easily ignore arguments pointed out by other agents, as well as how such arguments interact with her own ones); then, merging is used on the expanded systems as a way to solve the possible conflicts between them, and a set of argumentation systems which are as close as possible to the whole profile is generated; finally, the last step consists in selecting the acceptable arguments at the group levels from the set of argumentation systems.

In order to reach this goal, we first introduce a notion of *partial argumentation system*, which extends Dung’s argumentation system so as to represent *ignorance* concerning the attack relation. This is necessary in our setting since all the agents participating in the merging process are not assumed to share the same global set of arguments. Accordingly, the argumentation system furnished by each agent is first expanded into a partial argumentation system, and all such partial systems are built over the same set of arguments, those pointed out by at least one agent. Of course, there exist many different ways to incorporate a new argument into an argumentation system. Each agent can have her own expansion policy. We mention some possible policies, and focus on one of them, called the *consensual expansion*: when incorporating a new argument into her own system, an agent is ready to conclude that this argument attacks (resp. is attacked by) another argument whenever all the other agents who are aware of both arguments agree with this attack; otherwise, she concludes that she ignores whether an attack takes place or not.

Once all the expansions of the input argumentation systems have been computed, the proper merging step can be achieved; it consists in computing all the argumentation systems over the global set of arguments which are “as close as possible” to the partial systems generated during the last stage. Closeness is characterized by a notion of distance between an argumentation system and a profile of partial systems, induced from a primitive notion of distance between partial systems and an aggregation function. Several primitive distances and aggregation functions can be used; we mainly focus on the edit distance (which is, roughly speaking, the number of insertions/deletions of attacks needed to turn a given system into another one), and consider sum, max and leximax as aggregation functions.

Like the input of the overall merging process, the result of the merging step is a set of argumentation systems. However, while the first one reflects different points of view (since each system is provided by a specific agent), the second set expresses some uncertainty on the merging due to the presence of conflicts.

The last step of the process consists in defining the acceptable arguments for the group under the uncertainty provided by this set of argumentation systems. Once again, several sensible definitions are given. We show that the sets of arguments considered acceptable when the input is the set of argumentation systems primarily furnished by the agents may drastically differ from the sets of arguments considered acceptable after the merging step, and by means of example, we show that the latter ones are more in accordance with the intuition.

The rest of the paper is organized as follows. After a refresher on Dung's theory of argumentation (in which our approach takes place), we give a simple motivating example (Section 3) which shows that voting on the arguments accepted by each agent is not adequate for defining the arguments accepted by the group. Then we introduce a notion of partial argumentation system (Section 4) which extends the notion of argumentation system and enables to handle the case when agents do not share the same set of arguments. On this ground, we define a family of merging operators for argumentation systems (Section 5) and we study the properties of some of them (especially, those based on the edit distance) (Section 6). Then, we focus on acceptability for partial argumentation systems (Section 7). Finally, we conclude the paper and give a short presentation of some possible refinements of our framework (Section 8).

2 Dung's Theory of Argumentation

Let us present some basic definitions at work in Dung's theory of argumentation (13). We restrict them to finite argumentation frameworks.

Definition 1 (Argumentation system (AF))

A (finite) argumentation system $AF = \langle A, R \rangle$ over A is given by a finite set A of arguments and a binary relation R on A called an attack relation. $a_i R a_j$ means that a_i attacks a_j (also denoted by $(a_i, a_j) \in R$).

For our study, we are not interested in the structure of arguments and we consider an arbitrary attack relation.

$\langle A, R \rangle$ defines a directed graph \mathcal{G} called the *attack graph*.

Example 2 *The argumentation system $AF = \langle A = \{a_1, a_2, a_3, a_4\}, R = \{(a_2, a_3), (a_4, a_3), (a_1, a_2)\} \rangle$ defines the following graph \mathcal{G} :*

Acceptability is about the selection of the most acceptable arguments. Two mainstream approaches exist:

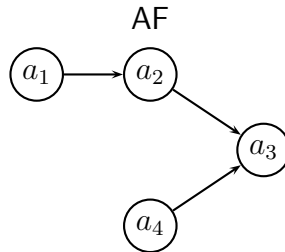

- *Individual acceptability*: acceptability of an *argument* depends only on its properties (see (16; 2));
- *Collective acceptability*: an argument can be defended by other arguments; in this case, the acceptability of a *set of arguments* is considered (see (13)).

Dung's theory is concerned with the second approach. Whether an argument can be accepted depends on the way arguments interact. Collective acceptability is based on two key notions: lack of conflict between arguments and collective defense.

Definition 3 ((13)) Let $\langle A, R \rangle$ be an argumentation system.

Conflict-free set A set $E \subseteq A$ is conflict-free if and only if $\nexists a, b \in E$ such that aRb .

Collective defense Consider $E \subseteq A$, $a \in A$. E (collectively) defends a if and only if $\forall b \in A$, if bRa , then $\exists c \in E$ such that cRb (a is said acceptable w.r.t. E). E defends all its elements if and only if $\forall a \in E$, E collectively defends a .

Dung defines several semantics for collective acceptability based on those two notions (13). Among them the *admissible semantics*, the *preferred semantics*, the *stable semantics* and the *grounded semantics*.

Definition 4 ((13)) Let $\langle A, R \rangle$ be an argumentation system.

Admissible semantics A set $E \subseteq A$ is admissible if and only if E is conflict-free and E defends all its elements.

Preferred semantics A set $E \subseteq A$ is a preferred extension if and only if E is maximal for set inclusion among the admissible sets.

Stable semantics A set $E \subseteq A$ is a stable extension if and only if E is conflict-free and every $a \in A \setminus E$ is attacked by an element of E .

Grounded semantics The grounded extension of $\langle A, R \rangle$ is the smallest subset of A with respect to set inclusion among the subsets of A which are admissible and coincide with the set of arguments acceptable w.r.t. itself.

Note that in all the above definitions, *each attacker* of a given argument is considered independently of the other attackers (there is no way to represent synergetic effects and the possibility to quantify all attackers as a whole is not considered – there exist other works which are concerned with this aspect,

see (19; 8; 6; 9; 10; 23)).

Definition 5 (Well-founded argumentation system (13))

An argumentation framework $AF = \langle A, R \rangle$ is well-founded if and only if there does not exist an infinite sequence $a_0, a_1, \dots, a_n \dots$ of arguments from A , such that for each i , $a_{i+1}Ra_i$.

Among other things, It is shown in (13) that:

- Any admissible set of $\langle A, R \rangle$ is included in a preferred extension of $\langle A, R \rangle$.
- Each $\langle A, R \rangle$ has at least one preferred extension.
- Each $\langle A, R \rangle$ has exactly one grounded extension of $\langle A, R \rangle$ and this extension is included in each preferred extension.
- If $\langle A, R \rangle$ is well-founded then it has a unique preferred extension which is also the only stable extension and the grounded extension.
- Any stable extension of $\langle A, R \rangle$ is also a preferred extension (the converse is false).
- Some $\langle A, R \rangle$ do not have a stable extension.

The acceptability status of each subset of arguments can now be defined by the following relation:

Definition 6 (Acceptability relation) *An acceptability relation, denoted by Acc_{AF} , for a given argumentation system $AF = \langle A, R \rangle$, is a total function from 2^A to $\{true, false\}$ which associates each subset E of A with true if E is an acceptable set for AF and with false otherwise.*

Usually, an acceptability relation is based on a specific semantics (plus a selection principle). For instance, a set of arguments can be considered acceptable if and only if it is included in one extension (credulous selection) or in every extension (skeptical selection). Alternatively, a set of arguments can be considered acceptable if and only if it coincides with one extension for the chosen semantics. Whatever the way it is defined, an acceptability relation can be viewed as a choice function among the elements of 2^A . In this context, the “acceptability of an argument” a can correspond either to the acceptability of the singleton $\{a\}$, or to the membership of a to an acceptable set (see (12)).

3 Simple is not so Beautiful

Given a profile (*i.e.*, a vector) $\mathcal{P} = \langle AF_1, \dots, AF_n \rangle$ of n AFs (with $n \geq 1$) where each $AF_i = \langle A_i, R_i \rangle$ represents the data given by Agent i , our purpose is to determine the subsets of $\bigcup_i A_i$ which are acceptable by the group of n agents. Voting is one way to achieve this goal.

3.1 Voting is not enough

Indeed, a simple approach to address the problem consists in considering a set of arguments acceptable for the group when it is acceptable for “sufficiently many” agents of the group. The voting method under consideration makes precise what “sufficiently many” means: it can be, for instance, simple majority. Let us illustrate such an approach on an example:

Example 7 Consider the three following argumentation systems:

- $AF_1 = \langle \{a, b, e, f\}, \{(a, b), (b, a), (e, f)\} \rangle$,
- $AF_2 = \langle \{b, c, d, e, f\}, \{(b, c), (c, d), (f, e)\} \rangle$,
- $AF_3 = \langle \{e, f\}, \{(e, f)\} \rangle$.

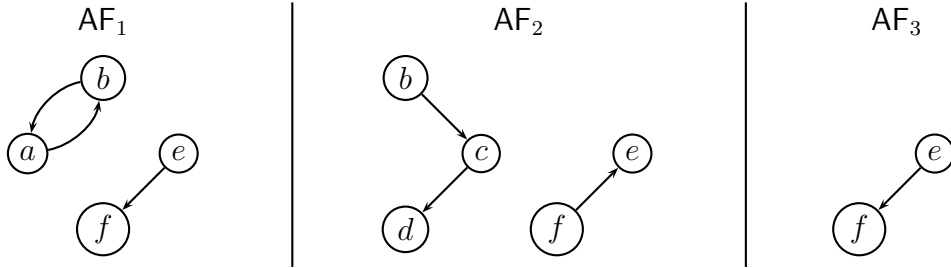

Whatever the chosen semantics (among Dung’s ones), c does not belong to any extension of AF_2 . As c is not known by the two other agents, it cannot be considered as acceptable by the group whatever the voting method (under the reasonable assumption that it is a choice function based on extensions, i.e., only subsets of an extension of an AF_i are eligible as acceptable sets). However since c (resp. a) is not among the arguments reported by the first agent and the third one (resp. the second and the third ones), it can be sensible to assume that the three agents agree on the fact that a attacks b , b attacks a and b attacks c . Indeed, this assumption is compatible with any of the three argumentation systems reported by the agents. Under this assumption, it makes sense to consider $\{c\}$ credulously acceptable for the group given that c is considered defended by a against b by Agent 1 and there is no conflicting evidence about it in the AF s provided by the two other agents.

As this example illustrates it, our claim is that, in general, voting is not a satisfying way to aggregate the data furnished by the different agents under the form of argumentation systems. Two problems arise:

Problem 1 Voting makes sense only if all agents consider the same set of arguments A at start (otherwise, the set 2^A of alternatives is not common to all agents). However, it can be the case that the sets of arguments reported by the agents differ from one another.

Problem 2 Voting relies only on the selected extensions: the attack relations (from which extensions are characterized) are not taken into consideration

any more once extensions have been computed. This leads to much significant information being set aside which could be exploited to define the sets of acceptable arguments at the group level.

3.2 Union is not merging (in general)

In order to solve both problems, a simple approach (at a first glance) consists in forming the union of the argumentation systems $\text{AF}_1, \dots, \text{AF}_n$, *i.e.*, considering the argumentation system denoted $\text{AF} = \bigcup_{i=1}^n \langle A_i, R_i \rangle$ and defined by $\text{AF} = \langle \bigcup_{i=1}^n A_i, \bigcup_{i=1}^n R_i \rangle$. Unfortunately, such a merging approach to argumentation systems cannot be taken seriously. Let us illustrate it on our running example:

Example 7 (continued) *The resulting AF is $\bigcup_{i=1}^3 \text{AF}_i = \langle \{a, b, c, d, e, f\}, \{(a, b), (b, a), (b, c), (c, d), (e, f), (f, e)\} \rangle$.*

Example 7 shows that the union approach to merging argumentation systems suffers from a major problem: it solves conflicts by giving to the explicit attack information some undue prominence to implicit non-attack information. Thus, when a pair of arguments (like, say (f, e)) does not belong to the attack relation furnished by an agent (say, Agent 1) while both arguments (f and e) belong to the set of arguments she points out, the meaning is that for Agent 1, argument f *does not attack* argument e . Imagine now that in the considered profile of argumentation systems, 999 agents report the same system as Agent 1, and the 1000th agent is Agent 2. In the resulting argumentation system considered at the group level, assuming that union is used as a merging operator, it will be the case that f attacks e while 999 agents over 1000 believes that it is not the case!

4 Partial Argumentation Systems

The example introduced in the previous section has illustrated that different cases must be taken into account:

- an argument exists in the argumentation system AF_1 of one of the agents and does not exist in the argumentation system AF_2 of at least another agent;
- an interaction between two arguments exists in the argumentation system AF_1 of one agent and does not exist in the argumentation system AF_2 of at least another agent.

In the first case, the new argument can be added to AF_2 but the question is what to do for the interactions between this new argument and the other arguments of AF_2 .

In the second case, things are different: if an interaction between two arguments a and b exists in a system AF_1 and not in another system AF_2 , even when a and b are in AF_2 , we cannot add the interaction in AF_2 (that Agent 2 did not include this attack in AF_2 is on purpose). Indeed, if an interaction is not present in an AF, it means that this interaction *does not exist* for the corresponding agent. The consequence of this is the necessity to discriminate among several cases whenever an argument a has to be added to an AF. Let b be an argument of the AF under consideration, three cases must be considered:

- the agent believes that the interaction (a, b) exists (attack);
- the agent believes that the interaction (a, b) does not exist (non-attack);
- the agent does not know whether the interaction (a, b) exists (ignorance).

The first two cases express the fact that the knowledge of the agent is sufficient for computing the new interaction concerning a . The third case expresses that the agent is not able to compute the new interaction concerning a and the arguments she pointed out (several reasons can explain it, especially a lack of information, or a lack of computational resources).

Handling these different kinds of information within a uniform setting calls for an extension¹ of the notion of argumentation systems, that we call *partial argumentation systems*.

Definition 8 (Partial argumentation system (PAF)) *A (finite) partial argumentation system over A is a quadruple $\text{PAF} = \langle A, R, I, N \rangle$ where*

- A is a finite set of arguments,
- R, I, N are binary relations on A :
 - R is the attack relation,
 - I is called the ignorance relation and is such that $R \cap I = \emptyset$,
 - and $N = (A \times A) \setminus (R \cup I)$ is called the non-attack relation.

N is deduced from A , R and I , so a partial argumentation system can be fully specified by $\langle A, R, I \rangle$. We use both notations in the following.

Each AF is a particular PAF for which the set I is empty (we say that such an AF is equivalent to the associated PAF). In an AF, the N relation also

¹ In (11), a new binary relation on the arguments is also introduced in Dung's argumentation framework : however, this new relation represents a notion of support between arguments. Clearly enough, this is unrelated with the relation introduced here representing the ignorance about the attack between arguments.

exists even if it is not given explicitly ($I = \emptyset$ and $N = A \times A \setminus R$). So, an AF could also be denoted by $\langle A, R, N \rangle$.

Each PAF over A can be viewed as a compact representation of a set of AFs over A , called its *completions*:

Definition 9 (Completion of a PAF) Let $\text{PAF} = \langle A, R, I \rangle$. Let $\text{AF} = \langle A, S \rangle$. AF is a completion of PAF if and only if $R \subseteq S \subseteq R \cup I$.

The set of all completions of PAF is denoted $\mathcal{C}(\text{PAF})$.

Example 10 The partial argumentation system $\text{PAF} = \langle A = \{a, b, c, d\}, R = \{(a, b), (a, c)\}, I = \{(c, a), (b, d)\}, N = \{(a, a), (b, b), (c, c), (d, d), (b, a), (b, c), (c, b), (a, d), (d, a), (d, b), (c, d), (d, c)\} \rangle$ is illustrated on the following figure (solid arrows represent the attack relation and dotted arrows represent the ignorance relation; non-attack relations are not represented explicitly as in the AF case):

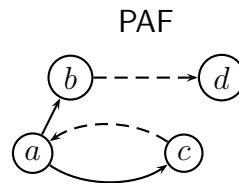

The completions of this PAF are:

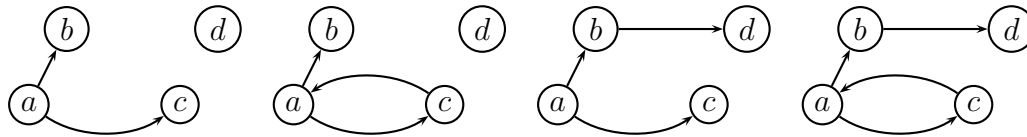

Now, **Problem 1** can be addressed by first associating each argumentation system AF_i with a corresponding PAF_i so that all PAF_i are about the same set of arguments $\bigcup_{i=1}^n A_i$. To this end, we introduce the notion of *expansion* of an AF:

Definition 11 (Expansion of an AF) Let $\mathcal{P} = \langle \text{AF}_1, \dots, \text{AF}_n \rangle$ be a profile of n AFs such that $\text{AF}_i = \langle A_i, R_i, N_i \rangle$. Let $\text{AF} = \langle A, R \rangle$ be an argumentation system. An expansion of AF given \mathcal{P} is any PAF $\text{exp}(\text{AF}, \mathcal{P})$ defined by $\langle A \cup \bigcup_i A_i, R', I', N' \rangle$ such that $R \subseteq R'$ and $(A \times A) \setminus R \subseteq N'$. exp is referred to as an expansion function.

In order to be general enough, this definition does not impose many constraints on the resulting PAF: what is important is to preserve the attack and non-attack relations from the initial AF while extending its set of arguments. Many policies can be used to give rise to expansions of different kinds, reflecting the various attitudes of agents in light of “new” arguments; for instance, if a is any argument considered by Agent i at the start and a “new” argument b has to be incorporated, Agent i can (among other things):

- always reject b (e.g., adding (b, b) to her relation R'_i),
- always accept b (adding (a, b) , (b, a) and (b, b) to her non-attack relation N'_i),
- just express her ignorance about b (adding (a, b) , (b, a) and (b, b) to her ignorance relation I'_i).

Each agent may also compute the exact interaction between a and b when the attack relation is not primitive but defined from more basic notions (as in the approach by Elvang-Gøransson et al., see e.g., (15; 16; 17)). Note that if she has limited computational resources, Agent i can compute exact interactions as far as she can, then express ignorance for the remaining ones.

In the following, we specifically focus on *consensual expansions*. Intuitively, the consensual expansion of an argumentation system $\text{AF} = \langle A, R \rangle$ given a profile of such systems is obtained by adding a pair of arguments (a, b) (where at least one of a, b is not in A) into the attack (resp. the non-attack relation) *provided that all other agents of the profile who know the two arguments agree on the existence of the attack*² (resp. *the non-attack*); otherwise, it is added to the ignorance relation.

This expansion policy is sensible as soon as each agent has a minimum level of confidence in the other agents: if a piece of information conveyed by one agent is not conflicting with the information stemming from the other agents, every agent of the group is ready to accept it.

Definition 12 (Consensual expansion) *Let $\mathcal{P} = \langle \text{AF}_1, \dots, \text{AF}_n \rangle$ be a profile of n AFs such that $\text{AF}_i = \langle A_i, R_i \rangle$. Let $\text{AF} = \langle A, R, N \rangle$ be an argumentation system. Let $\text{conf}(\mathcal{P}) = (\bigcup_i R_i) \cap (\bigcup_i N_i)$ be the set of interactions for which a conflict exists within the profile. The consensual expansion of AF over \mathcal{P} is the tuple denoted by $\text{exp}_C = \langle A', R', I', N' \rangle$ with:*

- $A' = A \cup \bigcup_i A_i$,
- $R' = R \cup ((\bigcup_i R_i \setminus \text{conf}(\mathcal{P})) \setminus N)$,
- $I' = \text{conf}(\mathcal{P}) \setminus (R \cup N)$,
- $N' = (A' \times A') \setminus (R' \cup I')$.

The next proposition states that, as expected, the consensual expansion of an argumentation system over a profile is an expansion:

Proposition 13 *Let $\mathcal{P} = \langle \text{AF}_1, \dots, \text{AF}_n \rangle$ be a profile of n AFs such that $\text{AF}_i = \langle A_i, R_i \rangle$. Let $\text{AF} = \langle A, R, N \rangle$ be an argumentation system. The consensual expansion exp_C of AF over \mathcal{P} is an expansion of AF over \mathcal{P} in the sense of Definition 11.*

² *i.e.*, if $a, b \in A_i$, then $(a, b) \in R_i$.

Proof : Consider $(a, b) \in A' \times A'$. There are several cases:

- if $(a, b) \in R$ then $(a, b) \in R'$ and $(a, b) \notin I' \cup N'$ (so, $R \subseteq R'$);
- if $(a, b) \notin R$ and $(a, b) \in N$ then $(a, b) \notin I' \cup R'$ and $(a, b) \in N'$ (so, $N \subseteq N'$);
- if $(a, b) \notin R \cup N$ then there are two cases:
 - if $\nexists AF_i \in \mathcal{P}$ such that $a, b \in A_i$ then $(a, b) \notin \text{conf}(\mathcal{P})$; so, $(a, b) \in N'$ and $(a, b) \notin R' \cup I'$;
 - if $\exists AF_i \in \mathcal{P}$ such that $a, b \in A_i$ then we have 4 possible cases:
 - if $(a, b) \in R_i$ and $\nexists AF_j \in \mathcal{P}$ such that $(a, b) \in N_j$ then $(a, b) \notin \text{conf}(\mathcal{P})$; so, $(a, b) \in R'$ and $(a, b) \notin N' \cup I'$;
 - if $(a, b) \in R_i$ and $\exists AF_j \in \mathcal{P}$ such that $(a, b) \in N_j$ then $(a, b) \in \text{conf}(\mathcal{P})$; so, $(a, b) \in I'$ and $(a, b) \notin R' \cup N'$;
 - if $(a, b) \in N_i$ and $\nexists AF_j \in \mathcal{P}$ such that $(a, b) \in R_j$ then $(a, b) \notin \text{conf}(\mathcal{P})$; so, $(a, b) \in N'$ and $(a, b) \notin R' \cup I'$;
 - if $(a, b) \in N_i$ and $\exists AF_j \in \mathcal{P}$ such that $(a, b) \in R_j$ then $(a, b) \in \text{conf}(\mathcal{P})$; so, $(a, b) \in I'$ and $(a, b) \notin R' \cup N'$.

So, R' , I' and N' form a partition of $A' \times A'$ which satisfies $R \subseteq R'$ and $N \subseteq N'$. \square

The consensual expansion is among the most cautious expansions one can define since it leads to adding a pair of arguments in the attack (or the non-attack relation) associated with an agent only when all the other agents agree on it.

Example 14 Consider the profile consisting of the following four argumentation systems:

- $AF_1 = \langle A_1 = \{a, b\}, R_1 = \{(a, b), (b, a)\} \rangle$,
- $AF_2 = \langle A_2 = \{b, c, d\}, R_2 = \{(b, c), (c, d)\} \rangle$,
- $AF_3 = \langle A_3 = \{a, b, d\}, R_3 = \{(a, b), (a, d)\} \rangle$,
- $AF_4 = \langle A_4 = \{a, b, d\}, R_4 = \{(b, d), (b, a)\} \rangle$.

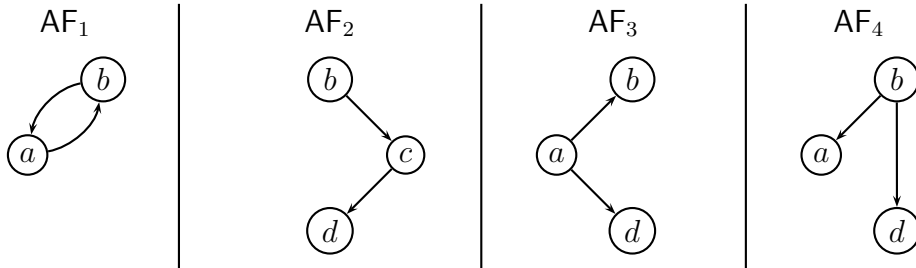

For each i , the consensual expansion PAF_i of AF_i is given by:

- $PAF_1 = \langle \{a, b, c, d\}, \{(a, b), (b, a), (b, c), (c, d)\}, \{(a, d), (b, d)\} \rangle$,
- $PAF_2 = \langle \{a, b, c, d\}, \{(b, c), (c, d)\}, \{(a, b), (b, a), (a, d)\} \rangle$,
- $PAF_3 = \langle \{a, b, c, d\}, \{(a, b), (a, d), (b, c), (c, d)\}, \{\} \rangle$,
- $PAF_4 = \langle \{a, b, c, d\}, \{(b, d), (b, a), (b, c), (c, d)\}, \{\} \rangle$.

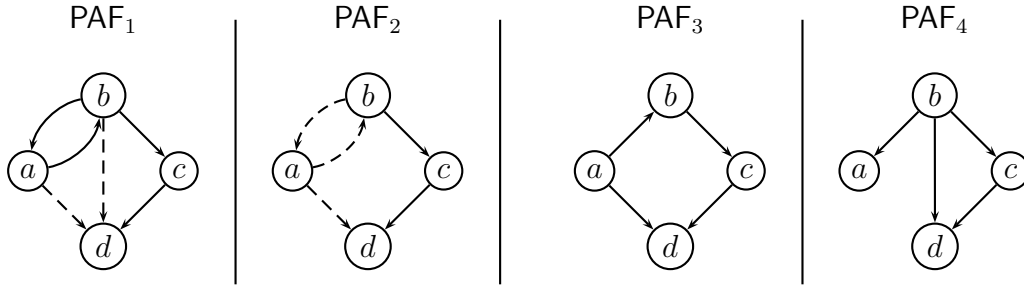

When the expansion policies considered by each agent are the same one exp , for any profile $\mathcal{P} = \langle \text{AF}_1, \dots, \text{AF}_n \rangle$ we shall often note $\text{exp}(\mathcal{P})$ the profile of PAFs $\langle \text{exp}(\text{AF}_1, \mathcal{P}), \dots, \text{exp}(\text{AF}_n, \mathcal{P}) \rangle$.

5 Merging Operators

In order to deal with **Problem 2**, we propose to merge interactions instead of sets of acceptable arguments. The goal is to characterize the argumentation systems which are as close as possible to the given profile of argumentation systems, taken as a whole.

A way to achieve this consists in defining a notion of “distance” between an AF and a profile of AFs, or more generally between a PAF and a profile of PAFs. This calls for a notion of pseudo-distance between two PAFs, and a way to combine such pseudo-distances:

Definition 15 (Pseudo-distance) *A pseudo-distance d between PAFs over A is a mapping which associates a non-negative real number to each pair of PAFs over A and satisfies the properties of symmetry ($d(x, y) = d(y, x)$) and minimality ($d(x, y) = 0$ if and only if $x = y$).*

d is a distance if it satisfies also the triangular inequality ($d(x, z) \leq d(x, y) + d(y, z)$).

Definition 16 (Aggregation function) *An aggregation function is a mapping \otimes from $(\mathbb{R}^+)^n$ to (\mathbb{R}^+) (strictly speaking, it is a family of mappings, one for each n), that satisfies*

- if $x_i \geq x'_i$, then $\otimes(x_1, \dots, x_i, \dots, x_n) \geq \otimes(x_1, \dots, x'_i, \dots, x_n)$ **(non-decreasingness)**
- $\otimes(x_1, \dots, x_n) = 0$ if $\forall i, x_i = 0$ **(minimality)**
- $\otimes(x) = x$ **(identity)**

The merging of a profile of AFs is defined as a set of AFs:

Definition 17 (Merging of n AFs) Let $\mathcal{P} = \langle \text{AF}_1, \dots, \text{AF}_n \rangle$ be a profile of n AFs. Let d be any pseudo-distance between PAFs, let \otimes be an aggregation function, and let $\text{exp}_1, \dots, \text{exp}_n$ be n expansion functions. The merging of \mathcal{P} is the set of AFs

$$\Delta_d^\otimes(\langle \text{AF}_1, \dots, \text{AF}_n \rangle, \langle \text{exp}_1, \dots, \text{exp}_n \rangle) = \\ \{ \text{AF over } \bigcup_i A_i \mid \text{AF minimizes } \otimes_{i=1}^n d(\text{AF}, \text{exp}_i(\text{AF}_i, \mathcal{P})) \}.$$

In order to avoid heavy notations, we shall sometimes identify the resulting set of AFs $\{\text{AF}'_1, \dots, \text{AF}'_k\}$ with the profile $\langle \text{AF}'_1, \dots, \text{AF}'_k \rangle$ (or any other permutation of it).

Thus, merging a profile of AFs $\mathcal{P} = \langle \text{AF}_1, \dots, \text{AF}_n \rangle$ is a two-step process:

expansion: An expansion of each AF_i over \mathcal{P} is first computed. Note that considering expansion functions specific to each agent is possible. What is important is that $\text{exp}_i(\text{AF}_i, \mathcal{P})$ is a PAF over $A = \bigcup_i A_i$.

fusion: The AFs over A that are selected as the result of the merging process are the ones that best represent \mathcal{P} (i.e., that are the “closest” to \mathcal{P} w.r.t. the aggregated distances).

In the following, we assume that each agent uses consensual expansion. In order to lighten the notations, we remove $\langle \text{exp}_1, \dots, \text{exp}_n \rangle$ from the list of parameters of merging operators.

Note that it would be possible to refine Definition 17 so as to include integrity constraints into the picture. This can be useful if there exists some (unquestionable) knowledge about the expected result (some attacks between arguments which have to hold for the group). It is then enough to look only to the AFs which satisfy the constraints, similarly to what is done in propositional belief base merging (see e.g., (20)). In contrast to the belief base merging scenario, constraints on the *structure* of the candidate AFs can also be set. In particular, considering only acyclic AFs can prove valuable since (1) such AFs are well-founded, (which implies that only one extension has to be considered whatever the underlying semantics – among Dung’s ones), and (2) this extension (which turns out to be the grounded one, see (13)) can be computed in time polynomial in the size of the AF (while computing a single extension is intractable for the other semantics in the general case – under the standard assumptions of complexity theory – see (14)).

Now, many pseudo-distances between PAFs and many aggregation functions can be used, giving rise to many merging operators. Usual aggregation functions include the sum Σ , the max $\mathcal{M}\text{ax}$ and the leximax $\mathcal{L}\text{eximax}$ ³ but using

³ When applied to a vector of n real numbers, the leximax function $\mathcal{L}\text{eximax}$ gives

non-symmetric functions is also possible (this may be particularly valuable if some agents are more important than others). Some aggregation functions (like the sum) enable the merging process to take into account the number of agents believing that an argument attacks or not another argument:

Example 7 (continued) *Two agents over three agree with the fact that e attacks f and f does not attack e . It may prove sensible that the group agrees with the majority.*

The choice of the aggregation function is very important for tuning the operator behaviour with the expected one. For example, sum is a possible choice in order to solve conflicts using majority. Otherwise, the leximax function can prove more valuable if the aim is to behave in a more consensual way, trying to define a result close to the AF of each agent of the group. The distinction between majority and arbitration operators as considered in propositional belief base merging (20) also applies here.

In the following, we focus on the *edit distance* between PAFs:

Definition 18 (Edit distance) *Let $\text{PAF}_1 = \langle A, R_1, I_1, N_1 \rangle$ and $\text{PAF}_2 = \langle A, R_2, I_2, N_2 \rangle$ be two PAFs over A .*

- *Let a, b be two arguments $\in A$. The edit distance between PAF_1 and PAF_2 over a, b is the mapping $de_{a,b}$ such that:*
 - $de_{a,b}(\text{PAF}_1, \text{PAF}_2) = 0$ if and only if $(a, b) \in R_1 \cap R_2$ or $I_1 \cap I_2$ or $N_1 \cap N_2$,
 - $de_{a,b}(\text{PAF}_1, \text{PAF}_2) = 1$ if and only if $(a, b) \in R_1 \cap N_2$ or $N_1 \cap R_2$,
 - $de_{a,b}(\text{PAF}_1, \text{PAF}_2) = 0.5$ otherwise.
- *The edit distance between PAF_1 and PAF_2 is given by*

$$de(\text{PAF}_1, \text{PAF}_2) = \sum_{(a,b) \in A \times A} de_{a,b}(\text{PAF}_1, \text{PAF}_2).$$

The edit distance between two PAFs is the (minimum) number of additions/deletions which must be made to render them identical. Ignorance is treated as halfway between attack and non-attack.

It is easy to show that:

Proposition 19 *The edit distance de between PAFs is a distance.*

Proof : We show that de and $de_{a,b}, \forall (a, b) \in A \times A$ are distances, *i.e.* they are (1) symmetric, they satisfy (2) the minimality requirement and (3) the triangular inequality:

(1) Obvious.

the list of those numbers sorted in a decreasing way. Such lists are compared w.r.t. the lexicographic ordering induced by the standard ordering on real numbers.

- (2) (\Rightarrow) Consider $\text{PAF}_1 = \langle A, R_1, I_1, N_1 \rangle$ and $\text{PAF}_2 = \langle A, R_2, I_2, N_2 \rangle$ such that $\text{PAF}_1 = \text{PAF}_2$. For all $(a, b) \in A \times A$, if $\text{PAF}_1 = \text{PAF}_2$ then $(a, b) \in R_1 \cap R_2$ or $(a, b) \in I_1 \cap I_2$ or $(a, b) \in N_1 \cap N_2$. So, $\forall (a, b) \in A \times A$, $de_{a,b}(\text{PAF}_1, \text{PAF}_2) = 0$, and $de(\text{PAF}_1, \text{PAF}_2) = 0$.
- (\Leftarrow) Suppose $de(\text{PAF}_1, \text{PAF}_2) = 0$ and make a *reductio ad absurdum*: if $\text{PAF}_1 \neq \text{PAF}_2$ then $\exists (a, b) \in A \times A$ such that $(a, b) \notin R_1 \cap R_2$, $(a, b) \notin I_1 \cap I_2$ and $(a, b) \notin N_1 \cap N_2$; so, $de_{a,b}(\text{PAF}_1, \text{PAF}_2) \neq 0$; so, $de(\text{PAF}_1, \text{PAF}_2) \neq 0$ which is a contradiction with the hypothesis; so, $\text{PAF}_1 = \text{PAF}_2$. The same reasoning can be achieved with $de_{a,b}(\text{PAF}_1, \text{PAF}_2) = 0$ and the same result is obtained: $\text{PAF}_1 = \text{PAF}_2$.
- (3) Consider $\text{PAF}_1 = \langle A, R_1, I_1, N_1 \rangle$, $\text{PAF}_2 = \langle A, R_2, I_2, N_2 \rangle$ and $\text{PAF}_3 = \langle A, R_3, I_3, N_3 \rangle$. $\forall (a, b) \in A \times A$, we compute and compare $de_{a,b}(\text{PAF}_1, \text{PAF}_2)$, $de_{a,b}(\text{PAF}_1, \text{PAF}_3)$ and $de_{a,b}(\text{PAF}_3, \text{PAF}_2)$, respectively denoted by x, y, z . We have three possible cases:
- $x = 0$: $\forall y, z$, we have $x \leq y + z$;
 - $x = 0.5$: $x \leq y + z$ is false if and only if $y = z = 0$; however, $y = z = 0$ implies that $(a, b) \in R_1 \cap R_2 \cap R_3$ or $(a, b) \in I_1 \cap I_2 \cap I_3$ or $(a, b) \in N_1 \cap N_2 \cap N_3$ which also implies $x = 0$ (contradiction with the hypothesis); so, $x \leq y + z$;
 - $x = 1$: we have $(a, b) \in R_1 \cap N_2$ or $(a, b) \in N_1 \cap R_2$; suppose that $(a, b) \in R_1 \cap N_2$ then there are 3 possible cases:
 - $(a, b) \in R_3$: so, $y = 0, z = 1$ and we have $x \leq y + z$;
 - $(a, b) \in I_3$: so, $y = 0.5, z = 0.5$ and we have $x \leq y + z$;
 - $(a, b) \in N_3$: so, $y = 1, z = 0$ and we have $x \leq y + z$.
- The same reasoning can be achieved if $(a, b) \in N_1 \cap R_2$. So, $\forall (a, b) \in A \times A$: $de_{a,b}(\text{PAF}_1, \text{PAF}_2) \leq de_{a,b}(\text{PAF}_1, \text{PAF}_3) + de_{a,b}(\text{PAF}_3, \text{PAF}_2)$;
- summing over all $(a, b) \in A \times A$, we get:
- $$de(\text{PAF}_1, \text{PAF}_2) \leq de(\text{PAF}_1, \text{PAF}_3) + de(\text{PAF}_3, \text{PAF}_2).$$

□

Let us now illustrate the notion of edit distance as well some associated merging operators on Example 14.

Example 14 (continued) *We consider the following argumentation system $\text{AF}'_1 = \langle \{a, b, c, d\}, \{(a, b), (b, a), (b, c), (c, d)\} \rangle$.*

The edit distance between AF'_1 and each of the PAFs $\text{PAF}_1, \text{PAF}_2, \text{PAF}_3, \text{PAF}_4$ obtained by consensual expansion from the profile $\langle \text{AF}_1, \text{AF}_2, \text{AF}_3, \text{AF}_4 \rangle$ is:

- $de(\text{AF}'_1, \text{PAF}_1) = 1,$
- $de(\text{AF}'_1, \text{PAF}_2) = 1.5,$
- $de(\text{AF}'_1, \text{PAF}_3) = 2,$
- $de(\text{AF}'_1, \text{PAF}_4) = 2.$

Taking the sum as the aggregation function, we obtain:

$$\sum_{i=1}^4 de(\text{AF}'_1, \text{PAF}_i) = 6.5.$$

Taking the max, we obtain: $\text{Max}_{i=1}^4 de(\text{AF}'_1, \text{PAF}_i) = 2$.

Taking the leximax, we obtain: $\text{Leximax}_{i=1}^4 de(\text{AF}'_1, \text{PAF}_i) = (2, 2, 1.5, 1)$.

By computing such distances for all candidate AFs (i.e., all AFs over $\{a, b, c, d\}$), we can compute the result of the merging:

$\Delta_{de}^{\Sigma}(\langle \text{AF}_1, \dots, \text{AF}_4 \rangle)$ is the set containing the two following AFs:

- $\text{AF}'_1 = \langle \{a, b, c, d\}, \{(a, b), (b, a), (b, c), (c, d)\} \rangle$,
- $\text{AF}'_2 = \langle \{a, b, c, d\}, \{(a, b), (b, a), (b, c), (a, d), (c, d)\} \rangle$.

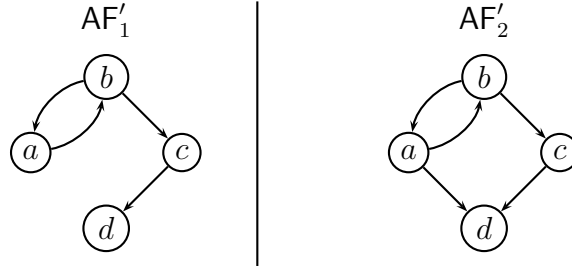

$\Delta_{de}^{\text{Max}}(\langle \text{AF}_1, \dots, \text{AF}_4 \rangle)$ is the set containing AF'_1 and $\text{AF}''_2 = \langle \{a, b, c, d\}, \{(b, a), (b, c), (a, d), (c, d)\} \rangle$.

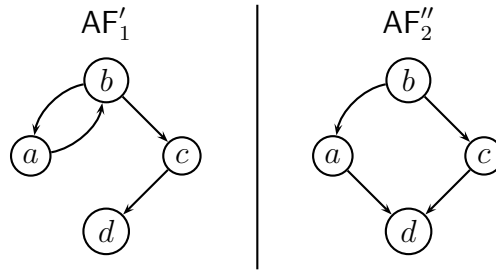

$\Delta_{de}^{\text{Leximax}}(\langle \text{AF}_1, \dots, \text{AF}_4 \rangle)$ is the singleton containing AF'_1 .

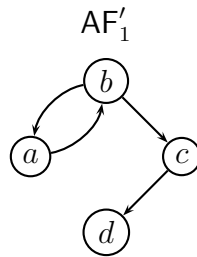

The discrepancies between the merging obtained with the various aggregation operators can be explained in the following way:

- AF'_1 is the most consensual AF obtained as it is almost equidistant from each PAF;
- AF'_2 is much closer to PAF_1 , PAF_2 and PAF_3 than to PAF_4 , thus it is selected with the sum as an aggregation operator but it is too far from PAF_4 for being selected with the Max or Leximax operators.

- AF_2'' is nearly equidistant from all four PAFs of the profile but less consensual than AF_1' , thus it is selected neither with Σ nor with $\mathcal{L}eximax$ but only with $\mathcal{M}ax$ as it is not far from any of the given PAFs.

Having AF_1' in all mergings - whatever the aggregation function chosen - seems very intuitive. Indeed, whenever an attack (or a non-attack) is present in the (weak) majority of the initial AFs, it is also in AF_1' . This is not the case for the two others AFs belonging to the above mergings.

Here is another simple example:

Example 20 Consider the two following argumentation systems:

- $AF_1 = \langle \{a, b, c, e\}, \{(b, a), (c, b), (c, e)\} \rangle$
- $AF_2 = \langle \{a, d, e, c\}, \{(d, a), (e, d), (e, c)\} \rangle$

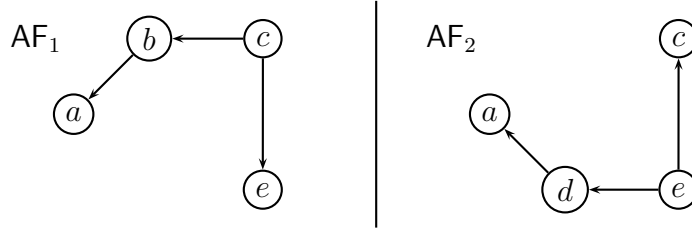

Note that the attack from c to e is known by Agent 1 but not by Agent 2 and the attack from e to c is known by Agent 2 but not by Agent 1. This illustrates the fact that the agents do not share the same attack relation.

AF_1 has a unique preferred extension: $\{c, a\}$. AF_2 has a unique preferred extension: $\{e, a\}$.

The consensual expansions of AF_1 and AF_2 are respectively:

- $PAF_1 = \langle \{a, b, c, d, e\}, \{(b, a), (c, b), (c, e), (d, a), (e, d)\}, \emptyset \rangle$,
- $PAF_2 = \langle \{a, b, c, d, e\}, \{(d, a), (e, d), (e, c), (b, a), (c, b)\}, \emptyset \rangle$.

The result of merging the profile $\langle AF_1, AF_2 \rangle$ with de and $\otimes = \mathcal{M}ax$ (or $\otimes = \mathcal{L}eximax$) is:

$$\Delta_{de}^{\mathcal{M}ax}(\langle AF_1, AF_2 \rangle) = \Delta_{de}^{\mathcal{L}eximax}(\langle AF_1, AF_2 \rangle) = \{AF_1', AF_2'\} \text{ with}$$

- $AF_1' = \langle \{a, b, c, d, e\}, \{(b, a), (c, b), (c, e), (d, a), (e, d), (e, c)\} \rangle$,
- $AF_2' = \langle \{a, b, c, d, e\}, \{(b, a), (c, b), (d, a), (e, d)\} \rangle$.

Using the sum as an aggregation function, two additional AFs are generated:

$$\Delta_{de}^{\Sigma}(\langle AF_1, AF_2 \rangle) = \{AF_1', AF_2', AF_3', AF_4'\} \text{ with}$$

- $AF_3' = \langle \{a, b, c, d, e\}, \{(b, a), (c, b), (c, e), (e, d), (d, a)\} \rangle$,
- $AF_4' = \langle \{a, b, c, d, e\}, \{(b, a), (c, b), (e, c), (e, d), (d, a)\} \rangle$.

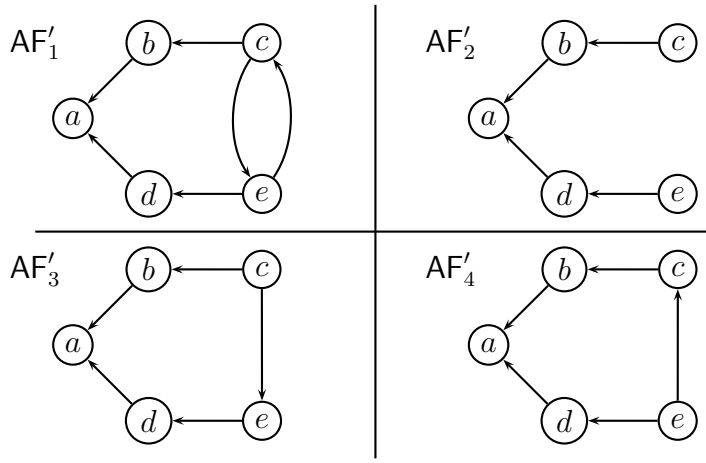

Each of the resulting mergings contains an argumentation system from which argument a can be derived, as it is the case in AF_1 and AF_2 . Using the sum as an aggregation function leads to the most consensual result here since it preserves the initial AFs of the different agents. Indeed, AF'_3 is equivalent to PAF_1 and AF'_4 is equivalent to PAF_2 .

6 Some Properties

Let us now present some properties of consensual expansions and merging operators based on the edit distance, showing them as interesting choices.

6.1 Properties of PAFs and consensual expansions

Intuitively speaking, a natural requirement on any AF resulting from a merging is that it preserves all the information which are shared by the agents participating in the merging process, and more generally, all the information on which the agents participating in the merging process do not disagree.

In order to show that our merging operators satisfy those requirements, one first need the notions of clash-free part and of common part of a profile of PAFs:

Definition 21 (Clash-free part of a profile of PAFs)

Let $\mathcal{P} = \langle PAF_1, \dots, PAF_n \rangle$ be a profile of PAFs. The clash-free part of \mathcal{P} is denoted by $CFP(\mathcal{P})$ and is defined by:

$$CFP(\mathcal{P}) = \langle \bigcup_i A_i, \bigcup_i R_i \setminus \bigcup_i N_i, I_{CFP}, \bigcup_i N_i \setminus \bigcup_i R_i \rangle$$

where $I_{CFP} = (\bigcup_i A_i \times \bigcup_i A_i) \setminus ((\bigcup_i R_i \setminus \bigcup_i N_i) \cup (\bigcup_i N_i \setminus \bigcup_i R_i))$.

The clash-free part of a profile of PAFs represents the pieces of information (attack / non-attack) that are not questioned by any other agent. As they are not the source of any disagreement, they are expected to be included in each AF resulting from the merging process.

Example 14 (continued) With $\mathcal{P} = \langle \text{AF}_1, \text{AF}_2, \text{AF}_3, \text{AF}_4 \rangle$, $CFP(\mathcal{P}) = \langle \{a, b, c, d\}, \{(b, c), (c, d)\}, \{(a, b), (b, a), (a, d), (b, d), (a, c), (c, a)\} \rangle$.

Note that with $\text{exp}_C(\mathcal{P}) = \langle \text{exp}_C(\text{AF}_1, \mathcal{P}), \dots, \text{exp}_C(\text{AF}_4, \mathcal{P}) \rangle$, $CFP(\text{exp}_C(\mathcal{P})) = \langle \{a, b, c, d\}, \{(b, c), (c, d)\}, \{(a, b), (b, a), (a, d), (b, d)\} \rangle$ (now (a, c) and (c, a) are non-attacks); so $CFP(\mathcal{P}) \neq CFP(\text{exp}_C(\mathcal{P}))$.

Definition 22 (Common part of a profile of PAFs)

Let $\mathcal{P} = \langle \text{PAF}_1, \dots, \text{PAF}_n \rangle$ be a profile of PAFs. The common part of \mathcal{P} is denoted by $CP(\mathcal{P})$ and is defined by: $CP(\mathcal{P}) = \langle \bigcap_i A_i, \bigcap_i R_i, \bigcap_i I_i, \bigcap_i N_i \rangle$.

The common part of a profile of PAFs is a much more demanding notion than the clash-free one. It represents the pieces of information on which all the agents agree. There is no doubt that those pieces of information must hold in any consensual view of the group's opinion, so the common part of the profile must be included in each AF of the result of the merging process.

Example 14 (continued) With $\mathcal{P} = \langle \text{AF}_1, \text{AF}_2, \text{AF}_3, \text{AF}_4 \rangle$, $CP(\mathcal{P}) = \langle \{b\}, \emptyset, \emptyset, \{(b, b)\} \rangle$.

We have the following easy property:

Proposition 23 Let $\mathcal{P} = \langle \text{PAF}_1, \dots, \text{PAF}_n \rangle$ be a profile of PAFs. The common part of \mathcal{P} is pointwise included into the clash-free part of \mathcal{P} , i.e.:

- $\bigcap_i R_i \subseteq \bigcup_i R_i \setminus \bigcup_i N_i$;
- $\bigcap_i I_i \subseteq I_{CFP}$;
- $\bigcap_i N_i \subseteq \bigcup_i N_i \setminus \bigcup_i R_i$.

Proof : The proof is straightforward:

- $\bigcap_i R_i \subseteq \bigcup_i R_i$ is obvious; and we also have $\forall (a, b) \in \bigcap_i R_i$, $(a, b) \notin N_j$ for all j (otherwise, $\exists \text{PAF}_k$ such that $(a, b) \in R_k \cap N_k$ that is impossible by definition), so $\bigcap_i R_i \subseteq \bigcup_i R_i \setminus \bigcup_i N_i$.
- In the same way, we can prove $\bigcap_i N_i \subseteq \bigcup_i N_i \setminus \bigcup_i R_i$.
- if $\forall (a, b) \in \bigcap_i I_i$ then, by definition, $(a, b) \notin R_i$ and $(a, b) \notin N_i$ for all i ; so, $(a, b) \in (\bigcup_i A_i \times \bigcup_i A_i) \setminus ((\bigcup_i R_i \setminus \bigcup_i N_i) \cup (\bigcup_i N_i \setminus \bigcup_i R_i))$.

□

The common part of a profile of n PAFs (resp. AFs) is not always a PAF

(resp. an AF). Contrastingly, the clash-free part of a profile of n PAFs is a PAF (however, the clash-free part of a profile of n AFs is not always an AF).

There exists an interesting particular case: if the various PAFs of the profile are based on the same set of arguments and if for each ordered pair of arguments (a, b) such that (a, b) belongs to the ignorance relation in one PAF, this pair belongs to the attack relation for another PAF of the profile and to the non-attack relation for at least a third PAF of the profile, then the clash-free part of the profile and its common part are identical:

Proposition 24 *Let $\mathcal{P} = \langle \text{PAF}_1, \dots, \text{PAF}_n \rangle$ be a profile of n PAFs over the same set of arguments A . Consider the clash-free part of \mathcal{P} denoted by $CFP(\mathcal{P}) = \langle A_{CFP}, R_{CFP}, I_{CFP}, N_{CFP} \rangle$ and the common part of \mathcal{P} denoted by $CP(\mathcal{P}) = \langle A_{CP}, R_{CP}, I_{CP}, N_{CP} \rangle$. If $\bigcup_i I_i \subseteq \text{conf}(\mathcal{P}) = (\bigcup_i R_i) \cap (\bigcup_i N_i)$, we have:*

- $A_{CFP} = A_{CP}$,
- $R_{CFP} = R_{CP}$,
- $N_{CFP} = N_{CP}$.

Proof : All the PAFs are over the same set of arguments, so we have $A = \bigcup_i A_i = \bigcap_i A_i$ and $A_{CFP} = A_{CP}$.

First, we prove that $R_{CFP} = R_{CP}$.

- $R_{CFP} \subseteq R_{CP}$: consider $(a, b) \in R_{CFP}$; so $(a, b) \in \bigcup_i R_i \setminus \bigcup_i N_i$; suppose that $(a, b) \notin R_{CP}$; so $\exists \text{PAF}_k$ such that $(a, b) \notin R_k$; so $(a, b) \in N_k$ or $(a, b) \in I_k$;
 In the first case, we have $(a, b) \notin \bigcup_i R_i \setminus \bigcup_i N_i$: contradiction with the hypothesis $(a, b) \in R_{CFP}$;
 In the second case, we retrieve the first case because $\bigcup_i I_i \subseteq \text{conf}(\mathcal{P}) = (\bigcup_i R_i) \cap (\bigcup_i N_i)$.
 Thus $(a, b) \in R_{CP}$.
- $R_{CFP} \supseteq R_{CP}$: given by Proposition 23.

$N_{CFP} = N_{CP}$ is proven in the same way. □

This result is interesting since this situation always holds (by definition) if consensual expansion is used as an expansion policy by each agent.

Example 14 (continued) *With $\mathcal{P} = \langle \text{AF}_1, \text{AF}_2, \text{AF}_3, \text{AF}_4 \rangle$ and $\text{exp}_C(\mathcal{P}) = \langle \text{exp}_C(\text{AF}_1, \mathcal{P}), \text{exp}_C(\text{AF}_2, \mathcal{P}), \text{exp}_C(\text{AF}_3, \mathcal{P}), \text{exp}_C(\text{AF}_4, \mathcal{P}) \rangle$, we have:*

- $CFP(\text{exp}_C(\mathcal{P})) = \langle \{a, b, c, d\}, \{(b, c), (c, d)\}, \{(a, b), (b, a), (a, d), (b, d)\}, \{(a, a), (b, b), (c, c), (d, d), (a, c), (c, a), (d, a), (d, b), (d, c), (c, b)\} \rangle$
- $CP(\text{exp}_C(\mathcal{P})) = \langle \{a, b, c, d\}, \{(b, c), (c, d)\}, \emptyset, \{(a, a), (b, b), (c, c), (d, d), (a, c), (c, a), (d, a), (d, b), (d, c), (c, b)\} \rangle$.

A valuable property of any consensual expansion over a profile of AFs is that

it preserves the clash-free part of the profile:

Proposition 25 *Let $\mathcal{P} = \langle \text{AF}_1, \dots, \text{AF}_n \rangle$ be a profile of AFs. For each i , we have:*

- $A_{CFP(\mathcal{P})} = A_{\text{exp}_C(\text{AF}_i, \mathcal{P})}$,
- $R_{CFP(\mathcal{P})} \subseteq R_{\text{exp}_C(\text{AF}_i, \mathcal{P})}$,
- $N_{CFP(\mathcal{P})} \subseteq N_{\text{exp}_C(\text{AF}_i, \mathcal{P})}$.

Proof : Consider AF_i , denoted by $\langle A_i, R_i, N_i \rangle$, and the set $\text{conf}(\mathcal{P}) = (\bigcup_i R_i) \cap (\bigcup_i N_i)$. Each $\text{exp}_C(\text{AF}_i, \mathcal{P})$ is denoted by $\langle A'_i, R'_i, I'_i, N'_i \rangle$.

- By definition, the set of arguments is the same for $CFP(\text{AF}_1, \dots, \text{AF}_n)$ and for each $\text{exp}_C(\text{AF}_i, \mathcal{P})$, $\forall \text{AF}_i$: it is equal to $\bigcup_i A_i$.
- Consider $a, b \in \bigcup_i A_i$ such that $(a, b) \in R_{CFP(\mathcal{P})} = (\bigcup_i R_i) \setminus (\bigcup_i N_i)$; so, we have $(a, b) \notin \text{conf}(\mathcal{P})$ and $(a, b) \notin N_i$. So, $(a, b) \in R'_i = R_i \cup ((\bigcup_i R_i) \setminus \text{conf}(\mathcal{P})) \setminus N_i$.
- Consider $a, b \in \bigcup_i A_i$ such that $(a, b) \in N_{CFP(\mathcal{P})} = (\bigcup_i N_i) \setminus (\bigcup_i R_i)$; so, we have $(a, b) \notin \text{conf}(\mathcal{P})$ and $(a, b) \notin \bigcup_i R_i$. So, $(a, b) \notin I'_i$, and $(a, b) \notin R'_i$. So, $(a, b) \in N'_i$.

□

Now, concordance between AFs can be defined as follows:

Definition 26 (Concordance) *Let $\text{AF}_1 = \langle A_1, R_1 \rangle$, $\text{AF}_2 = \langle A_2, R_2 \rangle$ be two AFs. AF_1, AF_2 are said to be concordant if and only if $\forall (a, b) \in (A_1 \cap A_2) \times (A_1 \cap A_2)$, $(a, b) \in R_1$ if and only if $(a, b) \in R_2$. Otherwise they are said to be discordant.*

Let $\mathcal{P} = \langle \text{AF}_1, \dots, \text{AF}_n \rangle$ be a profile of AFs. \mathcal{P} is said to be concordant if and only if all its AFs are pairwise concordant. Otherwise it is said to be discordant.

Of course, concordance is related to the set $\text{conf}(\mathcal{P})$ representing clashes between attack and non-attack relations in the different AFs of the profile:

Proposition 27 *Let $\mathcal{P} = \langle \text{AF}_1, \dots, \text{AF}_n \rangle$ be a profile of argumentation systems. \mathcal{P} is concordant if and only if $\text{conf}(\mathcal{P}) = \bigcup_i R_i \cap \bigcup_i N_i$ is empty.*

Proof : \mathcal{P} is concordant \Leftrightarrow

$$\forall \text{AF}_i, \text{AF}_j \in \mathcal{P}, \nexists a, b \in A_i \cap A_j \text{ such that } (a, b) \in (R_i \setminus R_j) \cup (R_j \setminus R_i) \Leftrightarrow$$

$$\forall \text{AF}_i, \text{AF}_j \in \mathcal{P}, \nexists a, b \in A_i \cap A_j \text{ such that } (a, b) \in R_i \text{ and } (a, b) \in N_j \Leftrightarrow$$

$$\bigcup_i R_i \cap \bigcup_i N_i = \emptyset. \quad \square$$

When a profile of AFs is concordant, its clash-free part is the union of its elements, and the converse also holds:

Proposition 28 *Let $\mathcal{P} = \langle \text{AF}_1, \dots, \text{AF}_n \rangle$ be a profile of AFs. \mathcal{P} is concordant if and only if $\text{CFP}(\mathcal{P}) = \bigcup_i \text{AF}_i$.*

Proof : $\text{CFP}(\mathcal{P})$ is denoted by $\langle A_{\text{CFP}}, R_{\text{CFP}}, I_{\text{CFP}}, N_{\text{CFP}} \rangle$.

The proof for “ \mathcal{P} concordant $\Rightarrow \text{CFP}(\mathcal{P}) = \bigcup_i \text{AF}_i$ ” is made using a *reductio ad absurdum*. We suppose that $\text{CFP}(\mathcal{P}) \neq \bigcup_i \text{AF}_i$ and we have the following possibilities:

- $\exists (a, b) \in R_{\text{CFP}}$ and $(a, b) \notin \bigcup_i R_i$; this case is impossible because, by definition, $(a, b) \in (\bigcup_i R_i) \setminus (\bigcup_i N_i)$;
- $\exists (a, b) \in N_{\text{CFP}}$ and $(a, b) \notin \bigcup_i N_i$; this case is impossible because, by definition, $(a, b) \in (\bigcup_i N_i) \setminus (\bigcup_i R_i)$;
- $\exists (a, b) \notin R_{\text{CFP}}$ and $(a, b) \in \bigcup_i R_i$; so, by definition, $(a, b) \in (\bigcup_i N_i)$; so, $\exists \text{AF}_k, \text{AF}_j$ such that $(a, b) \in R_k$ and $(a, b) \in N_j$; so, $\exists \text{AF}_k, \text{AF}_j$ such that $(a, b) \in A_k \cap A_j$ and $(a, b) \in R_k \setminus R_j$; so, contradiction with the hypothesis \mathcal{P} concordant;
- $\exists (a, b) \notin N_{\text{CFP}}$ and $(a, b) \in \bigcup_i N_i$; so, by definition, $(a, b) \in (\bigcup_i R_i)$; so, $\exists \text{AF}_k, \text{AF}_j$ such that $(a, b) \in R_k$ and $(a, b) \in N_j$; so, $\exists \text{AF}_k, \text{AF}_j$ such that $(a, b) \in A_k \cap A_j$ and $(a, b) \in R_k \setminus R_j$; so, contradiction with the hypothesis \mathcal{P} concordant.

For each possibility, we obtain a contradiction. So, if \mathcal{P} is concordant, then $\text{CFP}(\mathcal{P}) = \bigcup_i \text{AF}_i$.

The proof for “ \mathcal{P} concordant $\Leftarrow \text{CFP}(\mathcal{P}) = \bigcup_i \text{AF}_i$ ” is also made using a *reductio ad absurdum*. If \mathcal{P} is discordant then $\exists \text{AF}_i, \text{AF}_j$ such that $\exists (a, b) \in A_i \cap A_j$ and $(a, b) \in (R_i \setminus R_j) \cup (R_j \setminus R_i)$. So, $a, b \in \bigcup_k A_k$, $(a, b) \in \bigcup_k R_k$ and $(a, b) \in \bigcup_k N_k$; so, (a, b) appears in the attack relation and in the non-attack relation of $\bigcup_i \text{AF}_i$. However, by definition, (a, b) cannot appear in the same time in R_{CFP} and in N_{CFP} . So, contradiction with the hypothesis $\text{CFP}(\text{AF}_1, \dots, \text{AF}_n) = \bigcup_i \text{AF}_i$. \square

Proposition 29 *Let $\mathcal{P} = \langle \text{AF}_1, \dots, \text{AF}_n \rangle$ be a profile of AFs. \mathcal{P} is concordant if and only if $\text{exp}_C(\mathcal{P}) = \langle \text{exp}_C(\text{AF}_1, \mathcal{P}), \dots, \text{exp}_C(\text{AF}_n, \mathcal{P}) \rangle$ is reduced to $\langle \bigcup_i \text{AF}_i, \dots, \bigcup_i \text{AF}_i \rangle$ (i.e., each of the n elements of the vector is $\bigcup_i \text{AF}_i$).*

Proof : Consider a concordant profile of AFs \mathcal{P} . $\forall \text{AF}_i = \langle A_i, R_i, N_i \rangle$, let us consider $\text{exp}_C(\text{AF}_i, \mathcal{P}) = \langle A'_i, R'_i, I'_i, N'_i \rangle$. $\forall a, b \in \bigcup_i A_i$, there are several cases:

- if $(a, b) \in R_i$ then $(a, b) \in R'_i$;
- if $(a, b) \notin R_i$ and $(a, b) \in A_i \times A_i$ then $(a, b) \in N_i$, so $(a, b) \in N'_i$; with \mathcal{P} concordant, we also know that $\nexists \text{AF}_j \in \mathcal{P}$ such that $(a, b) \in R_j$;
- if $(a, b) \notin R_i$ and $(a, b) \notin A_i \times A_i$ then there are two cases:
 - either $\exists \text{AF}_j \in \mathcal{P}$ such that $(a, b) \in R_j$: because \mathcal{P} is concordant, $(a, b) \in$

R'_i ;

- or $\nexists \text{AF}_j \in \mathcal{P}$ such that $(a, b) \in R_j$: so, $(a, b) \in N'_i$.

In all the cases, if (a, b) is an attack interaction for one of the AF_i , (a, b) is also an attack interaction for the consensual PAFs. So, all the consensual PAFs are equal to $\bigcup_i \text{AF}_i$.

For the second part of the proof, consider $\text{exp}_C(\mathcal{P}) = \langle \bigcup_i \text{AF}_i, \dots, \bigcup_i \text{AF}_i \rangle$. We suppose that \mathcal{P} is discordant. So, $\exists \text{AF}_i, \text{AF}_j \in \mathcal{P}$ such that $\exists a, b \in A_i \cap A_j$ and $(a, b) \in (R_i \setminus R_j) \cup (R_j \setminus R_i)$. If we suppose that $(a, b) \in R_i$, then $\text{exp}_C(\text{AF}_j, \mathcal{P})$ cannot contain the attack (a, b) ; so, $\text{exp}_C(\text{AF}_j, \mathcal{P}) \neq \bigcup_i \text{AF}_i$: contradiction. And the same problem appears when we suppose that $(a, b) \in R_j$. So, \mathcal{P} is concordant. \square

Note that $\bigcup_i \text{AF}_i$ may appear into $\text{exp}_C(\mathcal{P})$, even if \mathcal{P} is discordant. This is illustrated by the following example:

Example 30 Consider the profile $\mathcal{P} = \langle \text{AF}_1, \text{AF}_2, \text{AF}_3 \rangle$ consisting of the following three AFs:

- $\text{AF}_1 = \langle \{a, b, c\}, \{(a, b), (a, c)\} \rangle$,
- $\text{AF}_2 = \langle \{a, b, c\}, \{(a, c)\} \rangle$,
- $\text{AF}_3 = \langle \{a, d\}, \{(a, d)\} \rangle$.

The profile $\mathcal{P} = \langle \text{AF}_1, \text{AF}_2, \text{AF}_3 \rangle$ is discordant and $\text{exp}_C(\mathcal{P}) = \langle \text{PAF}_1, \text{PAF}_2, \text{PAF}_3 \rangle$ is such that:

- $\text{PAF}_1 = \langle \{a, b, c, d\}, \{(a, b), (a, c), (a, d)\}, \emptyset \rangle (= \bigcup_i \text{AF}_i)$,
- $\text{PAF}_2 = \langle \{a, b, c, d\}, \{(a, c), (a, d)\}, \emptyset \rangle$,
- $\text{PAF}_3 = \langle \{a, b, c, d\}, \{(a, c), (a, d)\}, \{(a, b)\} \rangle$.

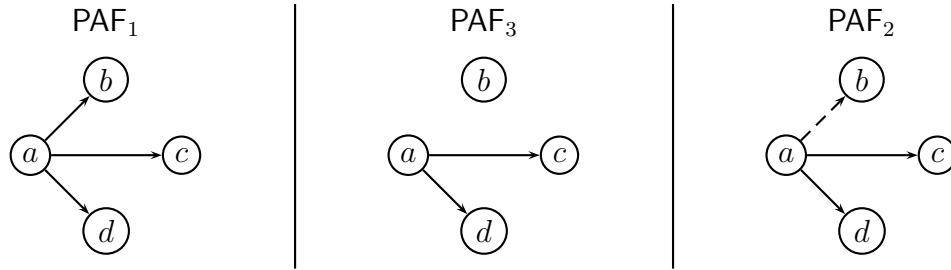

The following proposition states that whenever the presence of an attack (a, b) does not clash with a profile of AFs, such an attack is present in all the corresponding PAFs obtained by consensual expansion if and only if it is present in one of the input AFs.

Proposition 31 Let $\mathcal{P} = \langle \text{AF}_1, \dots, \text{AF}_n \rangle$ be a profile of AFs. Let (a, b) be a pair of arguments such that $a, b \in \bigcup_i A_i$ and $\nexists \text{AF}_i, \text{AF}_j \in \mathcal{P}$ such that $(a, b) \in (R_i \setminus R_j) \cup (R_j \setminus R_i)$.

$\exists \text{AF}_l \in \mathcal{P}$ such that $(a, b) \in R_l$ if and only if $\forall \text{AF}_k \in \mathcal{P}$, $(a, b) \in R'_k$ with R'_k denoting the attack relation of the PAF $\text{exp}_C(\text{AF}_k, \mathcal{P})$.

Proof : Consider $\text{AF}_k \in \mathcal{P}$. Since $\exists \text{AF}_l \in \mathcal{P}$ such that $(a, b) \in R_l$ and $\nexists \text{AF}_i, \text{AF}_j \in \mathcal{P}$ such that $(a, b) \in (R_i \setminus R_j) \cup (R_j \setminus R_i)$, $(a, b) \notin N_k$; so, $(a, b) \in R'_k$. The second part of the proof is obvious with a *reductio ad absurdum*: if we suppose that $\nexists \text{AF}_l \in \mathcal{P}$ such that $(a, b) \in R_l$ then we obtain $\forall \text{AF}_k \in \mathcal{P}$, $(a, b) \in N'_k$ which is a contradiction with $\forall \text{AF}_k \in \mathcal{P}$, $(a, b) \in R'_k$. \square

A notion of compatibility of a profile of PAFs over the same set of arguments can also be defined:

Definition 32 (Compatibility) Let $\mathcal{P} = \langle \text{PAF}_1, \dots, \text{PAF}_n \rangle$ be a profile of PAFs over a set of arguments A . $\text{PAF}_1, \dots, \text{PAF}_n$ are said to be compatible if and only if they have at least one common completion. Otherwise they are said to be incompatible.

Let $\mathcal{P} = \langle \text{AF}_1, \dots, \text{AF}_n \rangle$ be a profile of AFs. Let exp be an expansion function. $\text{AF}_1, \dots, \text{AF}_n$ are said to be compatible given exp if and only if $\text{exp}(\text{AF}_i, \mathcal{P})$, $\forall i = 1 \dots n$, are said to be compatible. Otherwise they are said to be incompatible.

There is a clear link between concordance and compatibility in the case of the consensual expansion applied to a profile of AFs:

Proposition 33 Let $\mathcal{P} = \langle \text{AF}_1, \dots, \text{AF}_n \rangle$ be a profile of AFs. \mathcal{P} is concordant if and only if $\text{exp}_C(\text{AF}_1, \mathcal{P}), \dots, \text{exp}_C(\text{AF}_n, \mathcal{P})$ are compatible.

Proof : The first part of the proof is obvious: if \mathcal{P} is concordant then the profile $\text{exp}_C(\mathcal{P}) = \langle \text{exp}_C(\text{AF}_1, \mathcal{P}), \dots, \text{exp}_C(\text{AF}_n, \mathcal{P}) \rangle$ is reduced to $\langle \bigcup_i \text{AF}_i, \dots, \bigcup_i \text{AF}_i \rangle$ (see Proposition 29); so, $\text{exp}_C(\text{AF}_1, \mathcal{P}), \dots, \text{exp}_C(\text{AF}_n, \mathcal{P})$ are equal and have a common completion.

The second part of the proof uses a *reductio ad absurdum*: if we suppose that \mathcal{P} is discordant then $\exists \text{AF}_i, \text{AF}_j$ such that $\exists (a, b) \in R_i \cap N_j$; so, $(a, b) \in R'_i$ with R'_i denoting the attack relation of $\text{exp}_C(\text{AF}_i, \mathcal{P})$ and $(a, b) \in N'_j$ with N'_j denoting the non-attack relation of $\text{exp}_C(\text{AF}_j, \mathcal{P})$; so, all the completions of $\text{exp}_C(\text{AF}_i, \mathcal{P})$ must contain the attack (a, b) and no completion of $\text{exp}_C(\text{AF}_j, \mathcal{P})$ can contain the attack (a, b) ; so, AF_i and AF_j do not have a common completion which is in contradiction with the hypothesis of compatibility. \square

Example 34 Consider the following argumentation systems AF_1, AF_2 and AF_3 .

The completions of their respective consensual expansions $\text{PAF}_1, \text{PAF}_2$ and

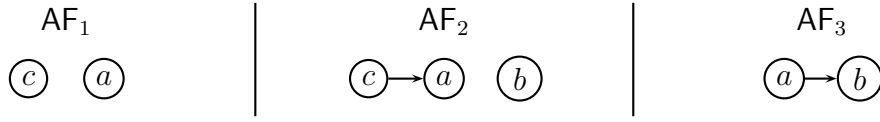

PAF₃ are:

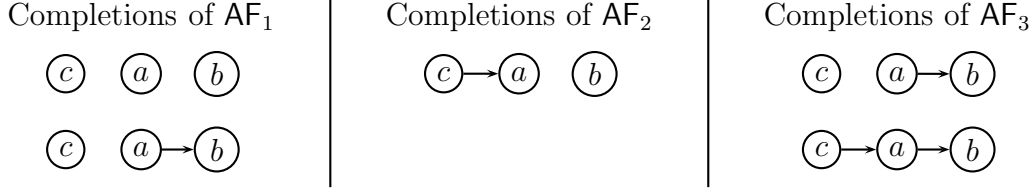

AF_1 and AF_2 are discordant and incompatible given exp_C . AF_3 and AF_1 are concordant and compatible given exp_C .

6.2 Properties of merging operators

Let us now give some properties of merging operators, focusing on those based on the edit distance:

Proposition 35 *Let $\mathcal{P} = \langle \text{AF}_1, \dots, \text{AF}_n \rangle$ be a profile of AFs. Assume that the expansion function used for each agent is the consensual one. If \mathcal{P} is concordant then $\Delta_{de}^\otimes(\mathcal{P}) = \{\cup_i \text{AF}_i\}$.*

Proof : If \mathcal{P} is concordant, then by Proposition 29, we have $\text{exp}_C(\langle \text{AF}_1, \dots, \text{AF}_n \rangle) = \langle \cup_i \text{AF}_i, \dots, \cup_i \text{AF}_i \rangle$. It remains to show that $\Delta_{de}^\otimes(\langle \cup_i \text{AF}_i, \dots, \cup_i \text{AF}_i \rangle) = \{\cup_i \text{AF}_i\}$, which is obvious since de , as a distance, satisfies the minimality requirement ($\cup_i \text{AF}_i$ is the unique PAF at edit distance 0 from itself). \square

Now we show an expected property: that the clash-free part of any profile \mathcal{P} is included in each AF from the merging of \mathcal{P} when the edit distance is used.

Proposition 36 *Let $\mathcal{P} = \langle \text{AF}_1, \dots, \text{AF}_n \rangle$ be a profile of argumentation systems. Assume that the expansion function used for each agent is the consensual one. For any aggregation function \otimes , we have that : $\forall \text{AF} = \langle A, R, N \rangle \in \Delta_{de}^\otimes(\langle \text{AF}_1, \dots, \text{AF}_n \rangle)$:*

- $A_{CFP(\mathcal{P})} \subseteq A$,
- $R_{CFP(\mathcal{P})} \subseteq R$,
- $N_{CFP(\mathcal{P})} \subseteq N$.

Proof : Let $CFP(\mathcal{P}) = \langle A_{CFP}, R_{CFP}, N_{CFP} \rangle$ (the ignorance relation does not appear here because argumentation systems (and not partial ones) are considered).

- $A_{CFP} = \bigcup_i A_i \subseteq A = \bigcup_i A_i$.
- By Proposition 25, we know that $CFP(\mathcal{P})$ is pointwise included in each $\text{exp}_C(\text{AF}_i, \mathcal{P})$. Let first consider the case $(a, b) \in R_{CFP}$, we have $(a, b) \in R_{\text{exp}_C(\text{AF}_i, \mathcal{P})}, \forall \text{AF}_i$.

Consider $\text{AF} = \langle A, R \rangle \in \Delta_{de}^\otimes(\langle \text{AF}_1, \dots, \text{AF}_n \rangle)$. Suppose that $(a, b) \notin R$ and consider $\text{AF}' = \langle A' = A, R' = R \cup \{(a, b)\} \rangle$.

$\forall \text{AF}_i, de(\text{AF}', \text{exp}_C(\text{AF}_i, \mathcal{P})) = de(\text{AF}, \text{exp}_C(\text{AF}_i, \mathcal{P})) - 1$, since $(a, b) \in R' \cap R_{\text{exp}_C(\text{AF}_i, \mathcal{P})}$ and $\notin R \cap R_{\text{exp}_C(\text{AF}_i, \mathcal{P})}$; so, since \otimes respects monotonicity, we have $\otimes_{i=1}^n de(\text{AF}', \text{exp}_C(\mathcal{P})) < \otimes_{i=1}^n de(\text{AF}, \text{exp}_C(\mathcal{P}))$ and we obtain a contradiction with $\text{AF} \in \Delta_{de}^\otimes(\langle \text{AF}_1, \dots, \text{AF}_n \rangle)$; so, $(a, b) \in R$. Hence $R_{CFP(\mathcal{P})} \subseteq R$.

- In the same way, we can prove that if $(a, b) \in N_{CFP}$ then $(a, b) \in N$. So $N_{CFP(\mathcal{P})} \subseteq N$.

□

As a direct corollary of Propositions 23 and 36, we get that:

Corollary 37 *Let $\mathcal{P} = \langle \text{AF}_1, \dots, \text{AF}_n \rangle$ be a profile of argumentation systems. Assume that the expansion function used for each agent is the consensual one. For any aggregation function \otimes , we have that: $\forall \text{AF} = \langle A, R, N \rangle \in \Delta_{de}^\otimes(\langle \text{AF}_1, \dots, \text{AF}_n \rangle)$:*

- $A_{CP(\mathcal{P})} \subseteq A$,
- $R_{CP(\mathcal{P})} \subseteq R$,
- $N_{CP(\mathcal{P})} \subseteq N$.

When sum is used as the aggregation function and all AFs are over the same set of arguments, the merging of a profile can be characterized in a concise way, thanks to the notion of majority graph. Intuitively the majority graph of a profile of AFs over the same set of arguments is the PAF obtained by applying the strict majority rule to decide whether a attacks b or not, for every ordered pair (a, b) of arguments. Whenever there is no strict majority, an ignorance edge is generated.

Definition 38 (Majority PAF) *Let $\mathcal{P} = \langle \text{AF}_1, \dots, \text{AF}_n \rangle$ be a profile of AFs over the same set A of arguments. The majority PAF $MP(\mathcal{P})$ of \mathcal{P} is the triple $\langle R, N, I \rangle$ such that $\forall a, b \in A$:⁴*

- $(a, b) \in R$ if and only if $\#\{i \in 1 \dots n \mid (a, b) \in R_i\} > \#\{i \in 1 \dots n \mid (a, b) \in N_i\}$;
- $(a, b) \in N$ if and only if $\#\{i \in 1 \dots n \mid (a, b) \in N_i\} > \#\{i \in 1 \dots n \mid (a, b) \in R_i\}$;

⁴ For any set S , $\#(S)$ denotes the cardinality of S .

- $(a, b) \in I$ otherwise.

The next proposition states that, as expected, the majority PAF of a profile of AFs over the same set of arguments is a PAF:

Proposition 39 *Let $\mathcal{P} = \langle \text{AF}_1, \dots, \text{AF}_n \rangle$ be a profile of AFs over the same set A of arguments. The majority PAF $MP(\mathcal{P})$ of \mathcal{P} is a PAF.*

Proof : Obvious since by construction, R and I are disjoint sets and N is the complement of $R \cup I$ into $A \times A$. \square

Example 40 *Consider $\text{AF}_1 = \langle \{a, b, c\}, \{(a, b), (b, c), (a, c)\} \rangle$, $\text{AF}_2 = \langle \{a, b, c\}, \{(a, b), (b, a), (a, c)\} \rangle$.*

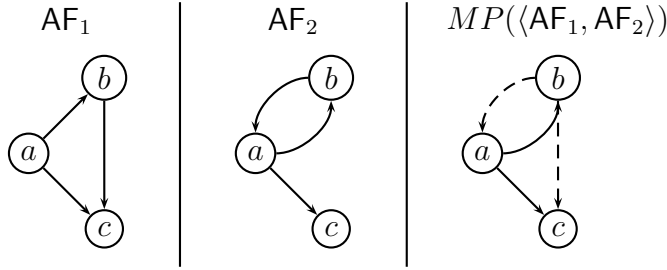

We have $MP(\langle \text{AF}_1, \text{AF}_2 \rangle) = \langle \{a, b, c\}, \{(a, b), (a, c)\}, \{(b, c), (b, a)\}, \{(a, a), (b, b), (c, c), (c, a), (c, b)\} \rangle$.

Proposition 41 *Let $\mathcal{P} = \langle \text{AF}_1, \dots, \text{AF}_n \rangle$ be a profile of AFs over the same set A of arguments. $\Delta_{de}^\Sigma(\mathcal{P}) = \mathcal{C}(MP(\mathcal{P}))$.*

Proof : The key is that the edit distance between an AF denoted by AF and a profile of AFs over A when Σ is the aggregation operator is the sum over the AF_i of the profile of the sum over every ordered pair of arguments over A of the edit distances between AF and AF_i (this is a consequence of the associativity of the sum).

Let AF be an AF over A which minimizes $\sum_{i=1}^n de(\text{AF}, \text{AF}_i)$. Let $a, b \in A$. If $\#\{i \in 1 \dots n \mid (a, b) \in R_i\} > \#\{i \in 1 \dots n \mid (a, b) \in N_i\}$, then (a, b) must be in the attack relation of AF ; otherwise, the AF AF' over A which coincides with AF except that (a, b) is in the attack relation of AF' would be such that $\sum_{i=1}^n de(\text{AF}', \text{AF}_i) < \sum_{i=1}^n de(\text{AF}, \text{AF}_i)$. Similarly, if $\#\{i \in 1 \dots n \mid (a, b) \in N_i\} > \#\{i \in 1 \dots n \mid (a, b) \in R_i\}$, then (a, b) must not be in the attack relation of AF .

In the remaining case, *i.e.*, when $\#\{i \in 1 \dots n \mid (a, b) \in R_i\} = \#\{i \in 1 \dots n \mid (a, b) \in N_i\}$, let AF' be the AF over A which coincides with AF except that (a, b) is in the attack relation of AF' if and only if (a, b) is not in the attack relation of AF . Then $\sum_{i=1}^n de(\text{AF}', \text{AF}_i) = \sum_{i=1}^n de(\text{AF}, \text{AF}_i)$.

This shows that every AF over A which minimizes $\sum_{i=1}^n de(\text{AF}, \text{AF}_i)$ is a completion of the majority PAF $MP(\mathcal{P})$.

Conversely, since every completion AF' of $MP(\mathcal{P})$ is such that $\sum_{i=1}^n de(\text{AF}', \text{AF}_i) = \sum_{i=1}^n de(\text{AF}, \text{AF}_i)$ where AF minimizes $\sum_{i=1}^n de(\text{AF}, \text{AF}_i)$, the conclusion follows. \square

Let us illustrate the previous proposition on Example 7:

Example 7 (continued) *The consensual expansions of AF_1 , AF_2 and AF_3 are respectively:*

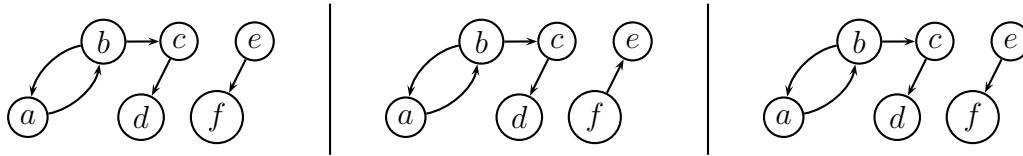

So, the majority PAF of $\langle \text{AF}_1, \text{AF}_2, \text{AF}_3 \rangle$ is:

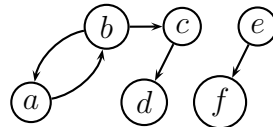

Using the edit distance and sum as the aggregation function, this PAF also represents the result of the merging in the sense that the latter is the set of all completions of this PAF.

Computing the majority PAF of a profile of AFs over the same set of arguments amounts to *voting on the attack relations* associated to each AF. As explained in Section 3, this can prove more suited to our goal than the approach which consists in voting directly on the acceptable sets of arguments for each agent. The previous proposition shows that such a simple voting approach corresponds to a specific merging operator in our framework (but many other operators, especially arbitration ones, can also be used).

7 Acceptability for Merged AFs

Starting from a profile of AFs (over possibly different sets of arguments), a merging operator enables the computation of a set of AFs (this time, over the same set of arguments) which are the best candidates to represent the AFs of the group (a kind of “consensus”).

There is an important epistemic difference between those two sets of AFs, the first one reflects different points of view given by different agents (and it can

be the case that two distinct agents give the same AF), while the second set expresses some uncertainty on the merging due to the presence of conflicts.

Let us recall that the main goal of this paper is to characterize the sets of arguments acceptable by the whole group of agents. In order to achieve it, it remains to define some mechanisms for exploiting the resulting set of AFs. This calls for a notion of joint acceptability.

Definition 42 (Joint acceptability) *A joint acceptability relation for a profile $\langle \mathbf{AF}_1, \dots, \mathbf{AF}_n \rangle$ of AFs, denoted by $Acc_{\langle \mathbf{AF}_1, \dots, \mathbf{AF}_n \rangle}$, is a total function from $2^{\bigcup_i A_i}$ to $\{true, false\}$ which associates each subset E of $\bigcup_i A_i$ with true if E is a jointly acceptable set for $\langle \mathbf{AF}_1, \dots, \mathbf{AF}_n \rangle$ and with false otherwise.*

For instance, a joint acceptability relation for a profile $\langle \mathbf{AF}_1, \dots, \mathbf{AF}_n \rangle$ can be defined by the acceptability relations $Acc_{\mathbf{AF}_i}$ (based themselves on some semantics and some selection principles), which can coincide for every \mathbf{AF}_i (but this is not mandatory) and a voting method $V : \{true, false\}^n \mapsto \{true, false\}$:

$$Acc_{\langle \mathbf{AF}_1, \dots, \mathbf{AF}_n \rangle}(E) = V(Acc_{\mathbf{AF}_1}(E), \dots, Acc_{\mathbf{AF}_n}(E)).$$

Here are some instances of Definition 42 based on voting methods:

Definition 43 (Acceptabilities for profiles of AFs) *Let $\mathcal{P} = \langle \mathbf{AF}_1, \dots, \mathbf{AF}_n \rangle$ be a profile of n AFs over the same set of arguments A . Let $Acc_{\mathbf{AF}_i}$ be the (local) acceptability relation associated with \mathbf{AF}_i . If $n = 1$, then we define $Acc_{\langle \mathbf{AF}_1 \rangle} = Acc_{\mathbf{AF}_1}$. Otherwise, for any subset S of A , we say that:*

- S is skeptically jointly acceptable for \mathcal{P} if and only if S is included in at least one acceptable set for each \mathbf{AF}_i :
 $\forall \mathbf{AF}_i \in \mathcal{P}, \exists E_i$ such that $Acc_{\mathbf{AF}_i}(E_i)$ is true and $S \subseteq E_i$.
- S is credulously jointly acceptable for \mathcal{P} if and only if S is included in at least one acceptable set for at least one \mathbf{AF}_i :
 $\exists \mathbf{AF}_i \in \mathcal{P}, \exists E_i$ such that $Acc_{\mathbf{AF}_i}(E_i)$ is true and $S \subseteq E_i$.
- S is jointly acceptable by majority for \mathcal{P} if and only if S is included in at least one acceptable set for at least a weak majority of \mathbf{AF}_i :
 $\#(\{\mathbf{AF}_i \mid \exists E_i \text{ such that } Acc_{\mathbf{AF}_i}(E_i) \text{ is true and } S \subseteq E_i\}) \geq \frac{n}{2}$.

Obviously enough, when none of the local acceptabilities $Acc_{\mathbf{AF}_i}$ is trivial (i.e., equivalent to the constant function *false*) for the profile under consideration, we have that any set of arguments which is skeptically jointly acceptable is also jointly acceptable by majority, and that any set of arguments which is jointly acceptable by majority is also credulously jointly acceptable.

Note that skeptical (resp. credulous) joint acceptability does not require that the skeptical (resp. credulous) inference principle is at work for defining local

acceptabilities $Acc_{\mathbf{AF}_i}$, which remain unconstrained.

Focusing on the preferred semantics together with credulous local acceptabilities, let us re-consider some previous examples:

Example 20 (continued) *Using the edit distance and $\otimes = \mathcal{L}eximax$ (or $\mathcal{M}ax$) as the aggregation function, we get two AFs \mathbf{AF}'_1 and \mathbf{AF}'_2 in the merging.*

If the local acceptability relations are based on credulous inference from preferred extensions, we have:

- $Acc_{\mathbf{AF}'_1}(E) = \text{true}$ if and only if $E \subseteq \{c, d\}$ or $E \subseteq \{b, e\}$;
- $Acc_{\mathbf{AF}'_2}(E) = \text{true}$ if and only if $E \subseteq \{a, c, e\}$.

$\{c\}$ and $\{e\}$ are skeptically jointly acceptable and $\{b, e\}, \{c, d\}$ and $\{a, c, e\}$ (and their subsets) are credulously (and by majority) jointly acceptable for the merging.

Using this method, the argument a can still be derived credulously, contrariwise to what happens when the union of the two AFs \mathbf{AF}_1 and \mathbf{AF}_2 is considered.

Example 7 (continued) *Using the edit distance and the sum as the aggregation function, we get one AF in the merging, denoted \mathbf{AF} :*

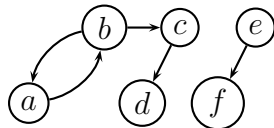

\mathbf{AF} has two preferred extensions : $\{a, c, e\}$ and $\{b, d, e\}$. So, $Acc_{\mathbf{AF}}(E) = \text{true}$ if and only if $E \subseteq \{a, c, e\}$ or $E \subseteq \{b, d, e\}$. The three joint acceptability relations coincide here (as there is only one AF in the result). The sets $\{a, c, e\}$ and $\{b, d, e\}$ (and their subsets) are credulously, skeptically and by majority, jointly acceptable for the merging, which is a more sensible result that the one obtained using a voting method on the derived arguments of the initial AFs (as explained in Section 3).

Example 14 (continued) *Using the edit distance and the sum as the aggregation function, we get two AFs in the merging:*

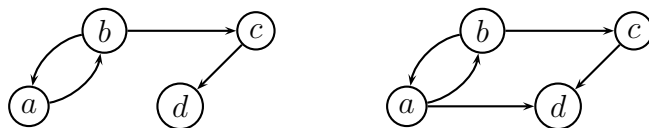

The preferred extensions for these 2 AFs coincide (they are $\{a, c\}$ and $\{b, d\}$). As the preferred extensions for the 2 AFs are the same ones, the three relations

of joint acceptability coincide here. Thus, the sets $\{a, c\}$ and $\{b, d\}$ (and their subsets) are skeptically, credulously and by majority jointly acceptable for the merging.

It is interesting to compare the joint acceptability relation for the input profile $\mathcal{P} = \langle \text{AF}_1, \dots, \text{AF}_n \rangle$ with the joint acceptability relation for the merging $\Delta_d^\otimes(\mathcal{P})$. Unsurprisingly, both predicates are not logically connected (*i.e.*, none of them implies the other one), even in the case when the two joint acceptability relations are based on the same notion of local acceptability (for instance, considering a set of arguments E as acceptable for an AF when it is included in at least one of its preferred extensions) and the same voting method (for instance, the simple majority rule).

Thus, it can be the case that new jointly acceptable sets are obtained after merging while they were not jointly acceptable at start:

Proposition 44 *Let $\mathcal{P} = \langle \text{AF}_1, \dots, \text{AF}_n \rangle$ be a profile of AFs over the same set of arguments A . The set of all jointly acceptable sets for the profile \mathcal{P} is not necessarily equal to the set of all jointly acceptable sets for the merging of \mathcal{P} .*

A counter-example is given by Example 14.

When each local acceptability relation corresponds exactly to the collective acceptability proposed by Dung (for a given semantics and $\forall \text{AF}_i, \text{Acc}_{\text{AF}_i}(E) = \text{true}$ if and only if E is an extension of AF_i for this semantics), the following remarks can be done:

- If a set of arguments is included in *one* of the acceptable sets for an agent, it is not necessarily included into one of the acceptable sets of any AF from the merging (and it also holds for singletons). The converse is also true.
- More surprisingly, even if a set of arguments is included into *each* acceptable set for an agent, it is not guaranteed to be included into an acceptable set of an AF from the merging. Conversely, if a set of arguments is included into every acceptable set of the AFs from the merging, it is not guaranteed to be included into an acceptable set for one of the agents. Intuitively, this can be explained by the fact that if an argument is accepted by all agents *for bad reasons* (for instance, because they lack information about attacks on it), it can be rejected by the group after the merging. More formally, this is due to the fact that nothing ensures that one of the initial AFs will belong to the result of the merging and also to the fact that acceptability is nonmonotonic (in the sense that adding a single attack (a, b) in an AF may drastically change its extensions).

8 Conclusion and Perspectives

We have presented a framework for deriving sensible information from a collection of argumentation systems *à la* Dung. Our approach consists in merging such systems. The proposed framework is general enough to allow for the representation of many different scenarios. It is not assumed that all agents must share the same sets of arguments. No assumption is made concerning the meaning of the attack relations, so that such relations may differ not only because agents have different points of view on the way arguments interact but more generally may disagree on what an interaction is. Each agent may be associated to a specific expansion function, which enables for encoding many attitudes when facing a new argument. Many different distances between PAFs and many different aggregation functions can be used to define argumentation systems which best represent the whole group.

By means of example, we have shown that our merging-based approach leads to results which are much more expected than those furnished by a direct vote on the (sets of) arguments acceptable by each agent. We have also shown that union cannot be taken as a valuable merging operator in the general case. We have investigated formally some properties of the merging operators which we point out. Among other results, we have shown that merging operators based on the edit distance preserve all the information on which all the agents participating in the merging process agree, and more generally, all the information on which the agents participating in the merging process do not disagree. We have also shown that the merging operator based on the edit distance and the sum as aggregation function is closely related to the merging approach which consists in voting on the attack relations when the input profile gathers argumentation systems over the same set of arguments. Finally, we have proven that in the general case, the derivable sets of arguments when joint acceptability concerns the input profile may drastically differ from the the derivable sets of arguments when joint acceptability concerns the profile obtained after the merging step.

We plan to refine our framework in several directions:

Merging PAFs. Our framework can be extended to PAFs merging (instead of AFs). This enables us to take into account agents with incomplete belief states regarding the attack relation between arguments. Expansions of PAFs can be defined in a very similar way to expansions of AFs (what mainly changes is the way ignorance is handled). As PAFs are more expressive than AFs, an interesting issue for further research is to define acceptability for PAFs.

Attacks strengths. Assume that each attack believed by Agent i is associated to a numerical value reflecting the strength of the attack according to the

agent, *i.e.*, the degree to which Agent i believes that a attacks b . It is easy to take into account those values by modifying slightly the definition of the edit distance over an ordered pair of arguments (for instance, viewing such values as weights once normalized within $[0, 1]$). Another possibility regarding attack strengths is, from unweighted attack relations, to generate a weighted one, representing different degrees of accordance in the group. For instance, each attack (a, b) in the majority PAF of a profile $\langle \text{AF}_1, \dots, \text{AF}_n \rangle$ can be labelled by the ratio $\frac{\#\{(i \in 1 \dots n \mid (a, b) \in R_i\}}{n}$ and similarly for the non-attack relation (this leads to consider both the attack and the non-attack relations of the majority PAF as fuzzy relations). Corresponding acceptability relations remain to be defined. This is another perspective of this work.

Merging audiences. In (7), an extension of the notion of AF, called valued AF — VAF for short —, has been proposed in order to take advantage of values representing the agent’s preferences in the context of a given audience. A further perspective of our work concerns the merging of such VAFs.

Acknowledgments

The authors are grateful to the anonymous referees for their helpful comments. This work has been partly supported by the Région Nord/Pas-de-Calais, the IRCICA consortium and by the European Community FEDER Program.

References

- [1] L. Amgoud and C. Cayrol. Inferring from inconsistency in preference-based argumentation frameworks. *Journal of Automated Reasoning*, 29:125–169, 2002.
- [2] L. Amgoud and C. Cayrol. A reasoning model based on the production of acceptable arguments. *Annals of Mathematics and Artificial Intelligence*, 34:197–216, 2002.
- [3] L. Amgoud, N. Maudet, and S. Parsons. Arguments, Dialogue and Negotiation. In *Proc. of ECAI’00*, pages 338–342, 2000.
- [4] L. Amgoud and S. Parsons. Agent dialogues with conflicting preferences. In *Intelligent Agents VIII: Agent theories, architectures and languages*, pages 190–205, 2002.
- [5] L. Amgoud and H. Prade. Reaching agreement through argumentation: A possibilistic approach. In *Proc. of KR’04*, pages 175–182, 2004.
- [6] T. Bench-Capon. Persuasion in practical argument using value-based argumentation frameworks. *Journal of Logic and Computation*, 13(3):429–448, 2003.
- [7] T. Bench-Capon, S. Doutre, and P.E. Dunne. Audiences in argumentation frameworks. *Artificial Intelligence*, 171:42–71, 2007.

- [8] P. Besnard and A. Hunter. A logic-based theory of deductive arguments. *Artificial Intelligence*, 128 (1-2):203–235, 2001.
- [9] A. Bochman. Collective argumentation and disjunctive programming. *Journal of Logic and Computation*, 13 (3):405–428, 2003.
- [10] C. Cayrol and M.-C. Lagasquie-Schiex. Graduality in argumentation. *Journal of Artificial Intelligence Research*, 23:245–297, 2005.
- [11] C. Cayrol and M.-C. Lagasquie-Schiex. On the acceptability of arguments in bipolar argumentation frameworks. In *Proc. of ECSQARU'05 – LNAI 3571*, pages 378–389. Springer-Verlag, 2005.
- [12] S. Coste-Marquis, C. Devred, and P. Marquis. Symmetric argumentation frameworks. In *Proc. of ECSQARU'05 – LNAI 3571*, pages 317–328, 2005.
- [13] P. M. Dung. On the acceptability of arguments and its fundamental role in nonmonotonic reasoning, logic programming and n-person games. *Artificial Intelligence*, 77:321–357, 1995.
- [14] P. Dunne and T. Bench-Capon. Coherence in finite argument systems. *Artificial Intelligence*, 141:187–203, 2002.
- [15] M. Elvang-Gøransson, J. Fox, and P. Krause. Acceptability of arguments as logical uncertainty. In *Proc. of ECSQARU'93 – LNCS 747*, pages 85–90, 1993.
- [16] M. Elvang-Gøransson, J. Fox, and P. Krause. Dialectic reasoning with inconsistent information. In *Proc. of UAI'93*, pages 114–121, 1993.
- [17] M. Elvang-Gøransson and A. Hunter. Argumentative logics: Reasoning with classically inconsistent information. *Data and Knowledge Engineering*, 16:125–145, 1995.
- [18] T. F. Gordon. *The Pleadings Game. An Artificial Intelligence Model of Procedural Justice*. Kluwer Academic, 1995.
- [19] H. Jakobovits and D. Vermeir. Robust semantics for argumentation frameworks. *Journal of Logic and Computation*, 9(2):215–261, 1999.
- [20] S. Konieczny and R. Pino Pérez. Merging information under constraints: a qualitative framework. *Journal of Logic and Computation*, 12(5):773–808, 2002.
- [21] P. Krause, S. Ambler, M. Elvang, and J. Fox. A logic of argumentation for reasoning under uncertainty. *Computational Intelligence*, 11 (1):113–131, 1995.
- [22] J. MacKenzie. Question-begging in non-cumulative systems. *Journal of Philosophical Logic*, 8:117–133, 1979.
- [23] S. Nielsen and S. Parsons. Computing preferred extensions for argumentation systems with sets of attacking arguments. In *Proc. of COMMA'06*, pages 97–108. IOS Press, 2006.
- [24] S. Parsons and N. R. Jennings. Negotiation through argumentation—a preliminary report. In *Proc. of ICMAS'96*, pages 267–274, 1996.
- [25] J. L. Pollock. Defeasible reasoning with variable degrees of justification. *Artificial Intelligence*, 133:233–282, 2001.
- [26] H. Prakken and G. Sartor. Argument-based extended logic programming with defeasible priorities. *Journal of Applied Non-Classical Logics*, 7:25–75, 1997.
- [27] H. Prakken and G. Vreeswijk. Logics for defeasible argumentation. In *Handbook of Philosophical Logic*, volume 4, pages 218–319. Kluwer Academic, 2002.
- [28] D. Walton and E. Krabbe. *Commitment in dialogue. Basic concepts of interpersonal reasoning*. State University of New York Press, 1995.